

## 0729-1755-99

# Dual Axis Inclinometer



### Description

The dual axis inclinometer in a compact, high-impact plastic housing offers microprocessor based electronics with 0-5 V output for easy use and interface with instrumentation and equipment. Assembly includes the Fredericks dual axis *TrueTilt* 0717-4318-99 sensor which provides long term repeatability and environmental durability in the most demanding applications.

- Angle range +/-60° (X & Y axis)
- Resolution .003 degrees
- Repeatability +/-0.1 Degrees
- Outputs (X& Y Axis) Analog 0-5 Volts  
PWM & Temperature
- Power Supply Voltage 7 to 16 VDC

### Operating Specifications

Output	0-5 Volts
Angle Range	*+/-60° (X&Y axis)
Resolution (.003 degrees)	0.2 Arc Minutes
Repeatability	+/- 0.1 degrees
Power supply voltage	7 to 16 VDC (regulated)
Power supply current	20mA @ 7VDC
Operating temperature range	-40°C to + 85°C
Storage temperature range	-40°C to + 85°C
Symmetry (typ.)	5%
Null Offset	5.0°
Mech. Crosstalk / Deg. (to 20°)	0.025°
Temperature Coefficient	
Null	20 arc sec / °C
Scale	0.1% / °C
Stability @ 24 hrs	0.1°

### Physical Dimensions

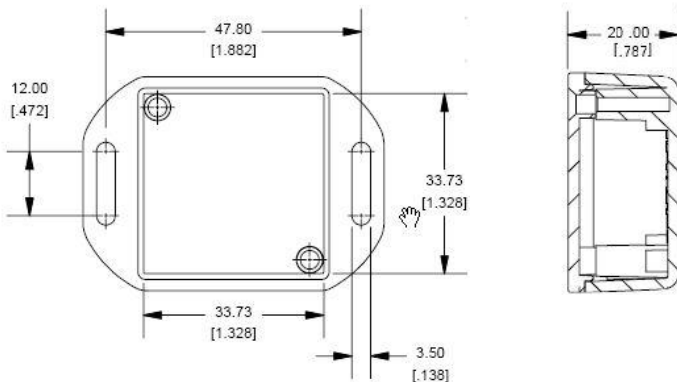

### Applications Include

- Solar Tracking
- Aerial Lift Platforms
- Construction machines
- Alarm System Activation
- Medical positioning and monitoring
- Machine tool leveling
- Mobile and stationary cranes

### Sensor Output Sensitivity Chart

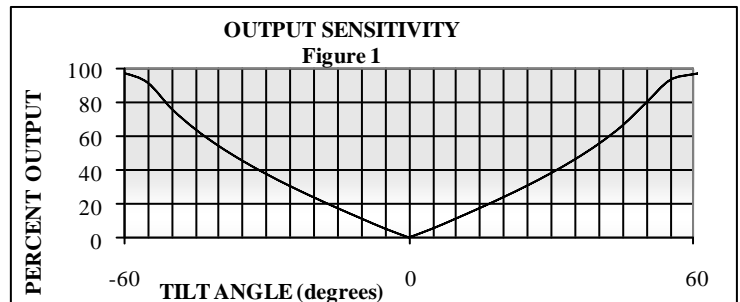

### Circuit Board Specifications

Wire color	Signal name	Direction	Description
RED	Vcc	Input	Supply voltage input: +7 to + 16 vdc
BLK	GND	-	Ground – The reference for the digital signals and the supply voltage
YEL	Temperature	Output	Voltage output from the on board temperature sensor MCP9700 Note: To convert the voltage from the on board MCP9700 use the following formula; Temp C = (MCP9700 output voltage – 0.5)/0.010
GRN	X axis analog	Output	X axis voltage output- ratiometric with internal 5V regulated supply voltage. For example: Null (zero degrees of angle) = 2.5 volts with supply voltage at 5V
BLU	Y axis analog	Output	Y axis voltage output- ratiometric with internal 5V regulated supply voltage. For example: Null (zero degrees of angle) = 2.5 volts with supply voltage at 5V
N/C*	X axis PWM	Output	X axis PWM output – 122 Hz duty cycle, 16 bit resolution (1% to 99%) For example: Null (zero degrees of angle) = 50% modulation
N/C*	Y axis PWM	Output	Y axis PWM output – 122 Hz duty cycle, 16 bit resolution (1% to 99%) For example: Null (zero degrees of angle) = 50% modulation

**Note:** The analog voltage output circuit is integrated from the PMW output. This circuit will be sensitive to moisture. Protected environment or conformal coating may be needed in higher humidity conditions.

**Note:** Installed sensor is 0717-4318-99, other sensors can be utilized per customer request.

\*Optional outputs can be provided upon request.