

250G CONTROL SERIES

DART

CONTROLS

Instruction Manual

Variable Speed DC Control



**P.O. Box 10
5000 W. 106th Street
Zionsville, Indiana 46077**

**Phone (317) 873-5211
Fax (317) 873-1105
www.dartcontrols.com**

TABLE OF CONTENTS

WARRANTY	1
INTRODUCTION	2
CONTROL FEATURES	2
HEATSINK DIMENSIONS	2
SPEEDPOT KIT ASSEMBLY	3
MOUNTING PROCEDURE	3
MODEL SELECTION	3
WIRING PROCEDURE & FUSING	4
TERMINAL STRIP WIRING	4
CHASSIS & ENCLOSED MODEL HOOK-UP DIAGRAMS	5
START-UP PROCEDURE & ADJUSTMENTS	6
TRIMPOT ADJUSTMENT PROCEDURE	6
TRIMPOT SETTING CHART	7
CONTROL MODIFICATIONS	7-8
TWO SPEED OPERATION	7
DYNAMIC BRAKING	7
TACH FEEDBACK & FOLLOWER	8
INHIBIT INSTRUCTIONS	8
OPTION DESCRIPTION	8-12
-5 OPTION	8
-7 / -9 OPTIONS	9
-11 / -17B / -29 / -29B / -34A OPTIONS	10
-55G2 / -56G2 CHASSIS OPTIONS & ADJUSTMENT PROCEDURE	11
-56G2 ENCLOSED OPTION	12
IN CASE OF DIFFICULTY	12
SPECIFICATIONS & TYPICAL MOTOR CURRENTS	13
250G SERIES PARTS PLACEMENT & LIST	13
250G SERIES SCHEMATIC	14
REPAIR PROCEDURE & PRODUCT LINE	BACK COVER

WARRANTY

Dart Controls, Inc. (DCI) warrants its products to be free from defects in material and workmanship. The exclusive remedy for this warranty is DCI factory replacement of any part or parts of such product which shall within 12 months after delivery to the purchaser be returned to DCI factory with all transportation charges prepaid and which DCI determines to its satisfaction to be defective. This warranty shall not extend to defects in assembly by other than DCI or to any article which has been repaired or altered by other than DCI or to any article which DCI determines has been subjected to improper use. DCI assumes no responsibility for the design characteristics of any unit or its operation in any circuit or assembly. This warranty is in lieu of all other warranties, express or implied; all other liabilities or obligations on the part of DCI, including consequential damages, are hereby expressly excluded.

NOTE: Carefully check the control for shipping damage. Report any damage to the carrier immediately. Do not attempt to operate the drive if visible damage is evident to either the circuit or to the electronic components.

All information contained in this manual is intended to be correct, however information and data in this manual are subject to change without notice. DCI makes no warranty of any kind with regard to this information or data. Further, DCI is not responsible for any omissions or errors or consequential damage caused by the user of the product. DCI reserves the right to make manufacturing changes which may not be included in this manual.

WARNING

Improper installation or operation of this control may cause injury to personnel or control failure. The control must be installed in accordance with local, state, and national safety codes. Make certain that the power supply is disconnected before attempting to service or remove any components!!! If the power disconnect point is out of sight, lock it in disconnected position and tag to prevent unexpected application of power. Only a qualified electrician or service personnel should perform any electrical troubleshooting or maintenance. At no time should circuit continuity be checked by shorting terminals with a screwdriver or other metal device.

INTRODUCTION

- The Dart 250G Series variable speed DC motor control is a versatile, general purpose control rated to 2 HP, available in chassis mount or enclosed configurations; with options for specific applications.
- The 251G model is available with an adjustable HP range of 1/50 thru 1/8 at 120 VAC input.
- The 253G model has a dual voltage input (may accommodate either 120 or 240 VAC). It is available with an adjustable HP range of 1/8 thru 1 HP for 120 VAC, and 1/4 thru 2 HP for 240 VAC input.
- Designed for DC Permanent Magnet, Shunt Wound, and some Universal (AC/DC) motors in the above horsepower ranges.
- Incoming AC voltage is also converted to adjustable full wave rectified DC voltage (via a packaged bridge) to operate the DC motor. Also, a full wave field voltage is provided for shunt wound motors (see page 4 for voltages).
- The control incorporates transient voltage protection with adjustable current limit and an AC fuse for protection. It features adjustable minimum and maximum speeds along with adjustable acceleration and IR Compensation. Tach feedback is accomplished thru a connection to a pin (P2) on the printed circuit board.
- The 250G Series has a linear acceleration/deceleration ramp.
- The control also has a barrier type terminal strip for all power and control wiring.
- The enclosed model uses a gasketed cover assembly that is rated NEMA 4/12.
- cU.L.us Listed.

CONTROL FEATURES

MIN. SPEED (minimum speed) - Allows adjustment of the motor speed when the speedpot is set at minimum (CCW). This permits the user to eliminate the “deadband” on the main speed control permitting zero calibration. Clockwise rotation of “MIN” trimpot increases minimum motor speed.

MAX. SPEED (maximum speed) - provides for adjustment of the motor speed when the speedpot is set at maximum (CW). This permits the user to eliminate the top end “deadband”, which will provide full speed at maximum rotation. Rotation of the “MAX” trimpot in the clockwise direction increases the maximum motor speed.

ACCEL (acceleration) - allows adjustment of the motor acceleration from a minimum of 0.5 seconds to approximately 8.0 seconds. The deceleration time depends on the ACCEL setting. For DECEL time equal to ACCEL time, see -17B option.

I. R. COMP (speed regulation) - adjusts the control output to compensate for speed changes caused by varying motor loads. As the motor load is increased, I.R. COMP increases the voltage output of the control. Clockwise rotation of the “I.R. COMP” trimpot will increase compensation.

CUR. LIM. (current limit) - provides protection from excessive armature current by limiting the maximum armature current the control can provide. This enables adjustment of the maximum torque the motor can deliver. Current limit adjustment (CUR LIM) is set at 125% of the rated motor current (torque) based on horsepower. Clockwise rotation of the “CUR LIM” trimpot increases the current (torque) the control will provide.

INHIBIT TERMINAL PIN (P2) - allows the user a choice of stopping and starting hard (fast) or stopping hard with a soft start through an adjustable acceleration ramp, without breaking the AC lines (see page 8).

TERMINAL STRIP - allows for connection of AC lines, motor leads, motor field (if needed), and speed potentiometer.

HEATSINK DIMENSIONS

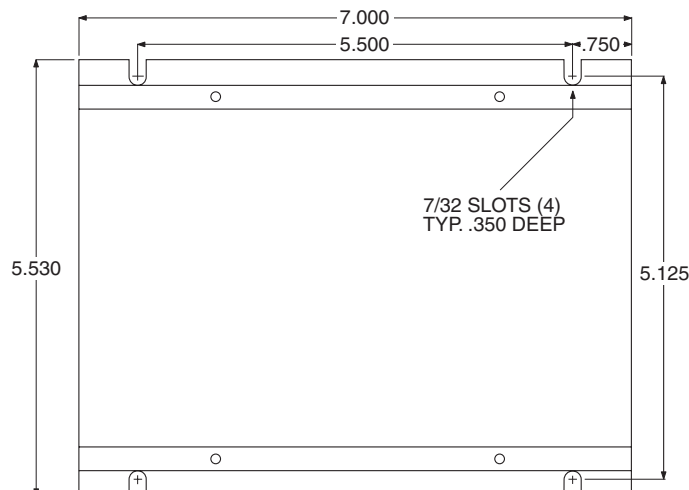

FOR CHASSIS VERSION: Allow 1.55" for height clearance, 7.00" for overall length.
FOR ENCLOSED VERSION: Allow 3.50" for height clearance, 7.40" for overall length.

SPEEDPOT KIT ASSEMBLY

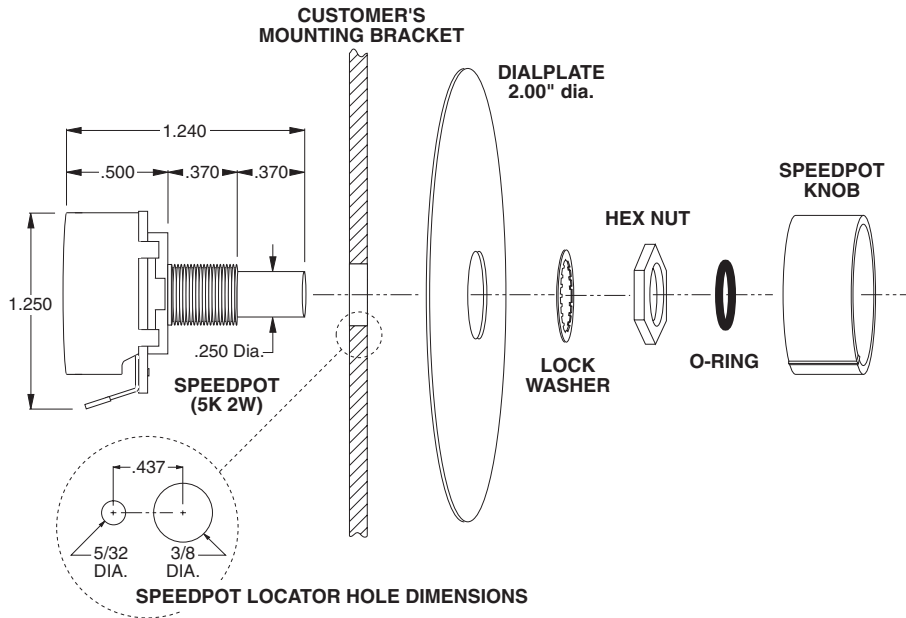

MOUNTING PROCEDURE

CAUTION: Do not mount control where ambient temperature is outside the range of -10° C. (15° F.) to 45° C. (115° F.)

1. Four 7/32" diameter slots are provided for control mounting.
2. The chassis of the control can be used as a template.
3. Use standard hardware to mount.
4. The enclosed version has two threaded holes (1/2" NPT) provided on the bottom side endplate near the terminal strip to facilitate wiring.

MODEL SELECTION

Note: The minimum current rating for all 250G controls is 150mA.

HORSEPOWER	INPUT VOLTAGE	OUTPUT VOLTAGE	OUTPUT AMPS DC	CHASSIS MODEL	ENCLOSED MODEL
1/50 1/20 1/8	120 VAC	0-90 VDC	1.2A	251G-12C	251G-12E
1/8 1/4 1/3 1/2 3/4 1.0	120/240 VAC	0-90/0-180 VDC	10.8A	253G-200C	253G-200E
1.5* 2.0*	240 VAC	0-180 VDC	10.8A	253G-200C	253G-200E

* Not available with 120 VAC input - Input voltage determines maximum allowable H.P.

The 251G will operate a 90 VDC motor in the H.P. range of 1/50 through 1/8 H.P., using different trimpot settings. The 253G will operate a 90 VDC motor in the H.P. range of 1/8 through 1 H.P., and a 180 VDC motor in the range of 1/4 through 2 H.P., using different trimpot settings.

WARNING

1. Be sure the control housing is properly grounded.
2. Arm connections must not be switched or broken while the control is on. Serious damage may result.
3. For non-speedpot applications, the input connections to the Lo-Wiper-Hi leads must not be grounded. Serious control damage may result from a grounded input.

WIRING PROCEDURE

1. **Size all wires** which carry armature or line current to handle currents as specified by national, state, and/or local codes. All other wires may be #18 AWG or smaller as permitted by local code.
2. **Separate control wires** from all the Armature and AC line wires when routed in conduits or in wire trays. The enclosed version has two threaded holes (1/2" NPT) in one endplate, located near the terminal strip, for this purpose.

FUSING

The 250G is provided with a fuse in AC line 1 (P1-11). This fuse is sized to open in the event of a shorted armature or if an armature line is shorted to earth ground. As long as 120 VAC input is connected properly, there is no additional fusing needed.

For 240 VAC applications, an external fuse may be used in AC line 2 (P1-10). This fuse should be a Bussman ABC10 or LittleFuse 314-010. This added fuse will provide protection on both AC legs to the 250G. If you desire not to fuse both legs, the fuse in the control will open in the event of excessive armature currents.

Note: AC current is determined by motor characteristics. In some applications it may be necessary to increase fuse value.

TERMINAL STRIP WIRING

The 250G Series has an 11 position terminal strip for ease of connection.

P1-1 (SPEEDPOT LO) Connects to low side (orange wire) of the 5K speedpot (normally the CCW end). This input is raised and lowered by the MIN. trimpot. Electronic speed input (voltage follower) may be referenced to speedpot LO if the MIN trimpot adjustments are to be active. Otherwise, inputs may be referenced to -ARM, which will bypass the MIN trimpot.

NOTE: INPUT MUST NOT BE GROUNDED!!

P1-2 (SPEEDPOT WIPER) Connects to wiper (red wire) of the 5K speedpot (center lead). For voltage follower applications, this **INPUT MUST NOT BE GREATER THAN +12 VOLTS MAXIMUM AND MUST NOT BE GROUNDED!**

P1-3 (SPEEDPOT HI) Connects to high side (white wire) of the 5K speedpot (CW end). This is internal +12 volts. For start-stop applications, the connection between this terminal and speedpot HI can be opened and closed by a SPST switch.

NOTE: INPUT MUST NOT BE GROUNDED!!

P1-4 (-ARM) Connects to minus (-) Armature wire (A2) on motor. For voltage follower applications where the MIN trimpot is bypassed, connect minus (-) of the follower to this terminal.

P1-5 (+ARM) Connects to plus (+) Armature wire (A1) on motor. 0-90 VDC for 120 VAC input OR 0-180 VDC for 240 VAC input. See "SPECIFICATIONS" for output rating.

P1-6 (+FIELD) DO NOT USE for permanent magnet motor. This supplies +Field voltage for a SHUNT WOUND MOTOR. Refer to Field Voltage table. For motors with dual voltage field (i.e. 50/100V or 100/200V), make sure highest value is connected.

FIELD VOLTAGE TABLE		
VAC INPUT	120	240
VDC FIELD	100	200

P1-7 (-FIELD) Connect minus (-) Field wire of SHUNT WOUND MOTOR.

P1-8 } VERY IMPORTANT !!! Refer to "CUSTOMER FUSING", shown above.

P1-9 } CHASSIS VERSION: (SPARE) Make no connection to P1-8 or P1-9

ENCLOSED VERSION: (AC) 120VAC - Connect incoming hot AC (black wire) to P1-9 and Neutral (white wire) to P1-8. Connect ground (green wire) to Chassis Ground, as shown in diagram - page 5.

240VAC - Connect both hot sides, one to P1-8 and one to P1-9. Also connect ground wire to Chassis Ground.

P1-10 } VERY IMPORTANT !!! Refer to "CUSTOMER FUSING", shown above.

P1-11 } CHASSIS VERSION: (AC) 120VAC - Connect incoming hot AC (brown or black wire) to P1-11 and Neutral (white or yellow wire) to P1-10. Connect ground (green wire) to Chassis Ground.

240VAC - Connect both hot sides, one to P1-10 and one to P1-11. Connect ground wire to Chassis Ground.

ENCLOSED VERSION: (SWITCHED AC) No connections to P1-10 and P1-11. This is for switched AC output. Note "FACTORY WIRING" (page 5). Pilot lights can be connected between these terminals. The voltage present at these terminals is AC input voltage.

250G SERIES CHASSIS HOOK-UP DIAGRAM

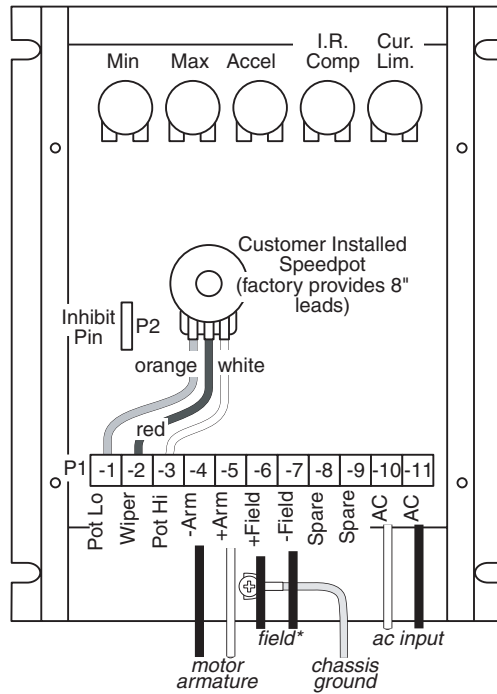

* Used for shunt wound motors only! No connection is made to these terminals when using permanent magnet motors.

250G SERIES ENCLOSED HOOK-UP DIAGRAM

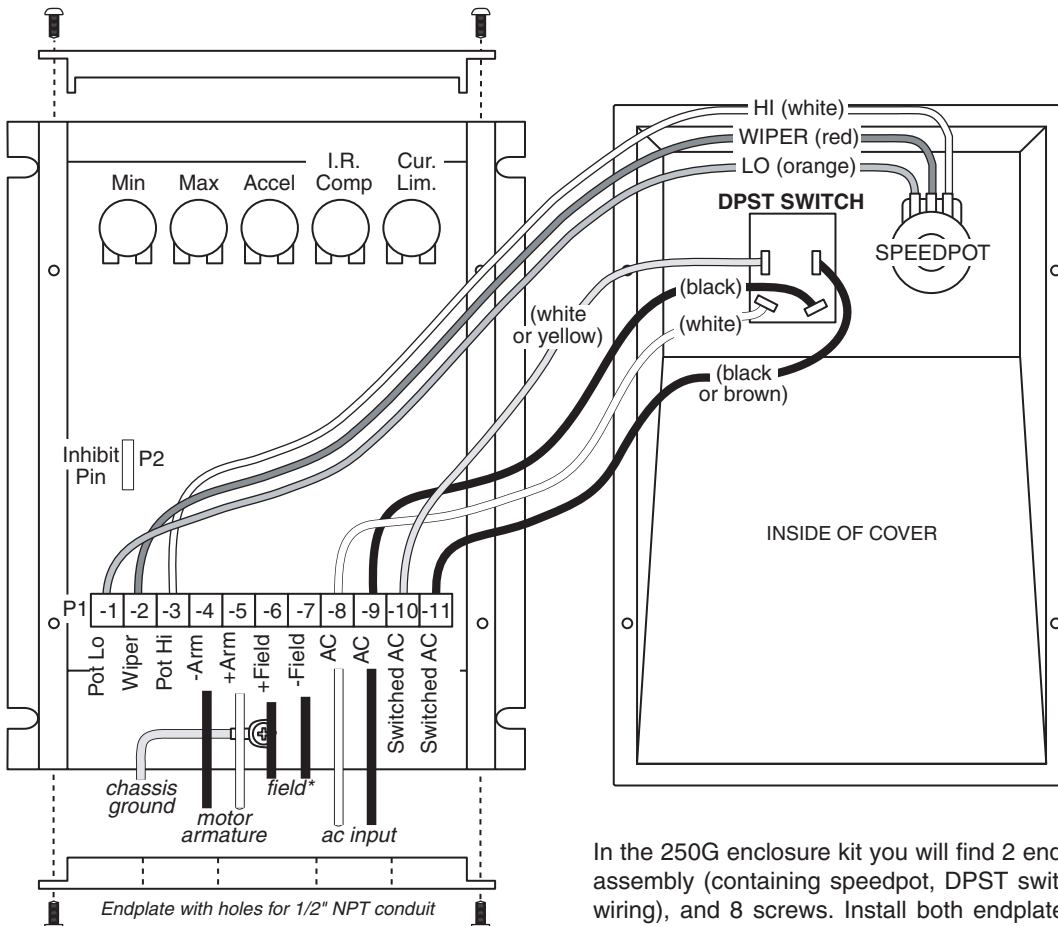

In the 250G enclosure kit you will find 2 endplates, a cover assembly (containing speedpot, DPST switch, gasket and wiring), and 8 screws. Install both endplates using (4) #5 screws, and the cover assembly, using (4) #6 screws. Before screwing down cover assembly, route wiring through conduit holes in endplate by terminal strip.

* Used for shunt wound motors only! No connection is made to these terminals when using permanent magnet motors.

Warning: Do not attempt to perform a Hi-Pot test across AC lines with control in circuit. This will result in immediate or long term damage to the control.

START-UP PROCEDURE

WARNING: ALL POWER MUST BE TURNED OFF BEFORE PROCEEDING !!!

1. Recheck all wiring. Accidental grounds, loose or pinched wires on armature or speedpot wires may damage the control when power is applied.
2. Check to see that incoming service is of correct voltage.
3. Turn speedpot to zero (fully CCW).
4. Turn power on and advance speedpot while observing motor.

WARNING: POWER MUST BE OFF BEFORE STEP 5 CAN BE ACCOMPLISHED!

5. If motor rotation is incorrect, turn power off at external disconnect and reverse +ARM and -ARM connections.
6. Check for satisfactory operation throughout the speed range.
7. If operation is satisfactory, no readjustments are needed.
8. If instability or surging is observed, or maximum speed is higher than desired, see section "TRIMPOT ADJUSTMENT".
9. For other problems, consult section "IN CASE OF DIFFICULTY".

ADJUSTMENTS

The trimpot adjustments, MIN, MAX, I.R. COMP, and CUR LIM are checked at the factory using a typical motor at 240 VAC input. Use the **TRIMPOT SETTING CHART** on page 7 to preset the trimpots for the proper setting for your application. The remaining trimpot - ACCEL, is a variable acceleration and should be set for your particular application.

The trimpot chart is approximate. The chart is valid when using the speedpot or a 0-10/12 VDC input signal to set speed.

These adjustments are permanent; periodic readjustment is normally not needed. Operation of the control beyond $\pm 10\%$ of normal line voltage could result in readjustments.

TRIMPOT ADJUSTMENT PROCEDURE

TRIMPOT	FUNCTION	ADJUSTMENT
MAX	<u>SETS MAXIMUM MOTOR SPEED</u> when speedpot is set at maximum (100% rotation CW). CW rotation of MAX trimpot increases maximum motor speed.	<ol style="list-style-type: none"> 1. TURN DRIVE POWER OFF!! 2. Connect DC Voltmeter: + to +ARM, - to -ARM. 3. Set meter voltage range: (90VDC or 180VDC). 4. Turn power on. Set speedpot at 100%. 5. Adjust MAX trimpot to rated motor armature voltage as shown on meter. <p>NOTE: A tachometer or strobe may be used in lieu of a meter. Follow above steps, except adjust MAX trimpot to rated motor base speed indicated by tachometer or strobe.</p>
MIN	<u>SETS MINIMUM MOTOR SPEED</u> when speedpot is set at zero. CW rotation will increase minimum motor speed.	<ol style="list-style-type: none"> 1. Set speedpot to zero (fully CCW). 2. Rotate MIN trimpot CW until motor rotates. 3. Slowly rotate MIN trimpot CCW until motor stops. NOTE: If motor rotation at zero is desired, rotate MIN trimpot CW until desired minimum speed is reached.
I.R. COMP.	<u>CALIBRATES SPEED REGULATION</u> - Provides a means of improving motor speed regulation in the armature feedback mode. If a slowdown due to load change is of no concern, rotate this trimpot fully CCW.	<ol style="list-style-type: none"> 1. Set speedpot at 50%. 2. Observe motor speed at no load condition. 3. Apply a full load to the motor. 4. Adjust IR COMP trimpot CW to obtain the same motor speed as with no load.
CUR. LIM.	<u>LIMITS DC MOTOR ARMATURE CURRENT</u> (Torque) to prevent damage to the motor or control. The current limit is set for the rated motor current. CW rotation of this trimpot increases the armature current (or torque produced).	<ol style="list-style-type: none"> 1. TURN DRIVE POWER OFF !! 2. Connect a DC ammeter between A1 on the motor and +ARM on the control. This is in series with the motor. 3. Turn power on. 4. Set speedpot at the 50% position. 5. Set CUR LIM trimpot fully CCW. 6. Apply friction braking to the motor shaft until motor is stalled (zero RPM). 7. While motor is stalled, set current at 125% of rated nameplate motor armature current by adjusting the CUR LIM trimpot.
ACCEL	<u>ALLOWS ADJUSTMENT OF ACCELERATION</u> by user.	<ol style="list-style-type: none"> 1. CW rotation increases time of acceleration.

TRIMPOT SETTING CHART

- * These settings apply when using a 5000Ω Master Speedpot.
- * Settings will differ when using various options, such as the -5 or the -7 option.
For the -17B option, Accel/Decel is 20 seconds when pot is turned fully clockwise.
- * This trimpot chart is approximate. Use it in conjunction with the Adjustment Procedures.

	MIN	MAX	ACCEL	I.R.	C.L.	H.P.	INPUT VOLTAGE	OUTPUT VOLTAGE
2 1 G						1/50	120VAC	0-90VDC
						1/20	120VAC	0-90VDC
						1/8	120VAC	0-90VDC
2 3 G						1/8	120VAC	0-90VDC
						1/4	120VAC	0-90VDC
						1/3	120VAC	0-90VDC
						1/2	120VAC	0-90VDC
						3/4	120VAC	0-90VDC
						1.0	120VAC	0-90VDC

	MIN	MAX	ACCEL	I.R.	C.L.	H.P.	INPUT VOLTAGE	OUTPUT VOLTAGE
2 5 G						1/4	240VAC	0-180VDC
						1/2	240VAC	0-180VDC
						3/4	240VAC	0-180VDC
2 3 G						1.0	240VAC	0-180VDC
						1.5	240VAC	0-180VDC
						2.0	240VAC	0-180VDC

CONTROL MODIFICATIONS

TWO SPEED OPERATION

Two pot operation is done using two 10K ohm speed potentiometers in parallel (both HI's to P1-3, both LO's to P1-1). The WIPER is switched using a SPDT switch.

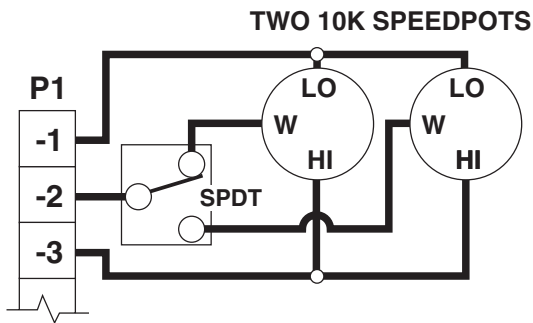

DYNAMIC BRAKING

A DPDT switch is used to inhibit the control and to connect the DBR. Typical values for the DBR (dynamic brake resistor) are 5 ohms for 120V, 10 ohms for 240V (both 35W to 50W). Note that motor horsepower, inertia, and cycle time effect sizing of the DBR. **NOTE: This modification cannot be used with the -17B option.**

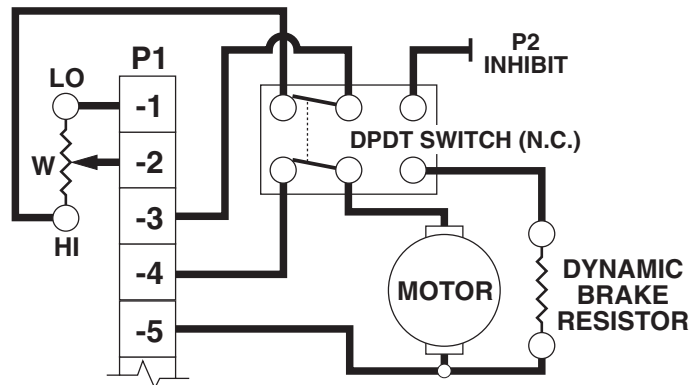

TACHOMETER FEEDBACK

Improves speed regulation to $\pm 1/2\%$ of base speed. Control goes to full output when input goes to zero, above and beyond MAX trimpot setting

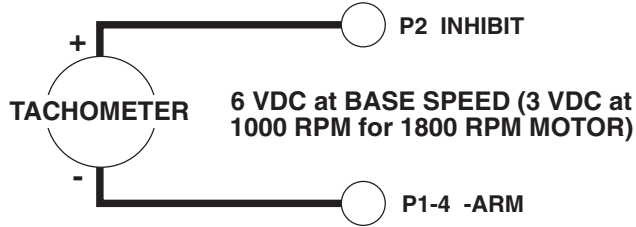

TACHOMETER FOLLOWER

Allows control output to follow tachometer voltage.

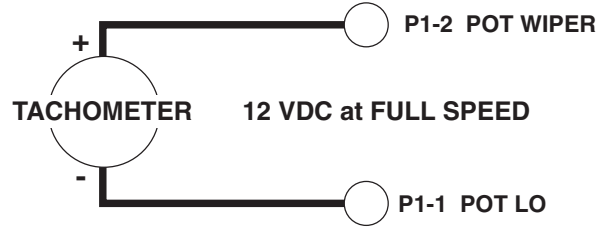

NOTE: NEED 1% OR LESS - TACH OUTPUT RIPPLE

INHIBIT (USED INDEPENDENTLY)

The customer supplied SPST switch is connected in series between the speedpot HI (P1-3) and the Inhibit pin (P2). To inhibit, speedpot HI is closed to the Inhibit pin. To restart, the switch is returned to open. NOTE: The control will stop and start fast, accel is bypassed.

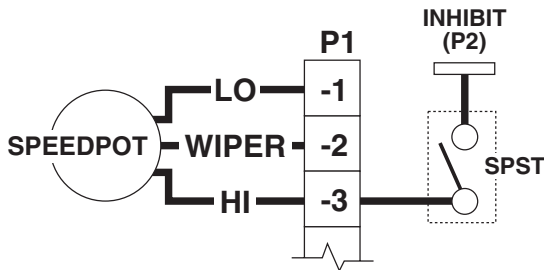

INHIBIT (USED WITH SPEEDPOT)

The Common of the SPDT switch is connected to control pot HI and is switched between Speedpot Hi and the Inhibit pin (P2). To inhibit (stop motor), speedpot HI is closed to the Inhibit pin. To restart, the switch is returned to Speedpot Hi. NOTE: The control will stop fast and soft start through a fixed acceleration range.

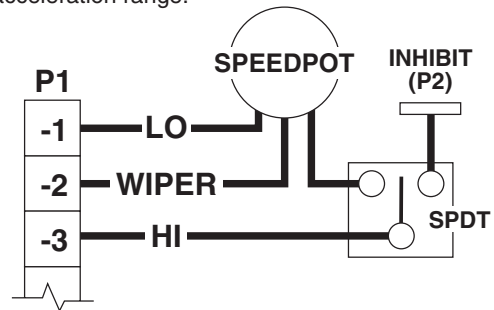

NOTE: Permits starting and stopping of motor without breaking AC lines. In the event of SCR failure or false triggering, the Inhibit circuit will not stop motor.

Always use a shielded wire when connecting to the inhibit terminal. The shield should be connected to -Armature or Common of the control.

OPTION DESCRIPTION

-5 option

Isolated 4-20 ma.Signal Follower

**Field or Factory Installed
Available on Chassis Only***

4 to 20mA -5

Input impedance: 500 ohms or less

DO NOT USE TRIMPOT CHART TO ADJUST MIN AND MAX TRIMPOTS ON MAIN BOARD. IF ADJUSTMENT IS NEEDED THEN REFER TO THE SETUP PROCEDURE BELOW.

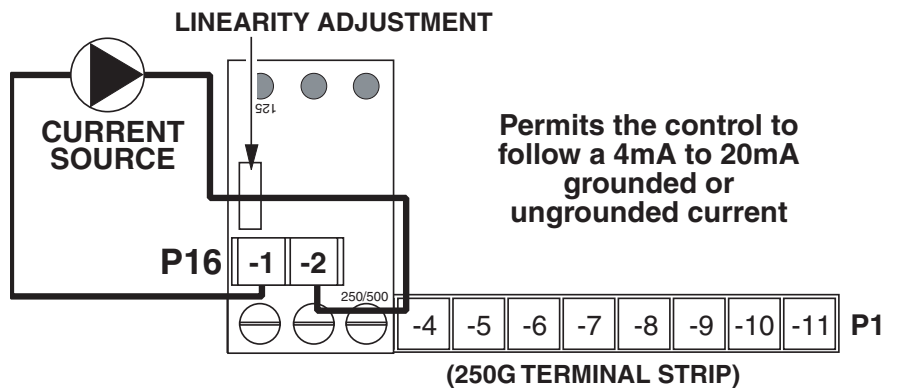

This option replaces the speedpot with a 4-20 ma. signal to control speed. The current signal input can be either grounded or ungrounded. The board sets on spacers screwed to terminals P1-1, P1-2, and P1-3 on the main board using long screws. The current source connects to the + and - two position terminal strip (P16-1 and -2) on the -5 option board.

The Linearity trimpot on the -5 option board is set at the factory for proper linearity, however this trimpot may need to be re-set after tuning the controls Max and Min trimpot settings for your specific application. If needed then refer to the setup procedure below.

Setting the Min, Max and Linearity Trimpots.

1. Preset the multi-turn Linearity trimpot on the -5 option board full CW, set the Min trimpot full CCW and set the Max trimpot at about 50% rotation.
2. Input a 4 ma. current signal to the control and turn the Min trimpot CW to your desired minimum output voltage or to deadband (the point just before you begin to get an output).
3. Input a 20 ma. current signal to the control and set the Max trimpot to the desired maximum speed setting.
4. With 20 ma. still going to the control, turn the Linearity trimpot CCW until your output speed starts to decrease. Then slowly turn it back CW until you just reach your maximum speed setting.

- For enclosed models use -7 option.

Note: This jumper wire is not used with some options. Consult factory if more than one option is being wired. Using the JU2 jumper wire when not required may cause permanent damage to the control.

-7 option

**Isolated 4-20 ma. Signal Follower
with Auto/Manual Switch**

Enclosed - Factory Installed only

Chassis - Factory or Field Installed

Chassis - switch & wiring are customer provided

Input impedance: 500 ohms or less

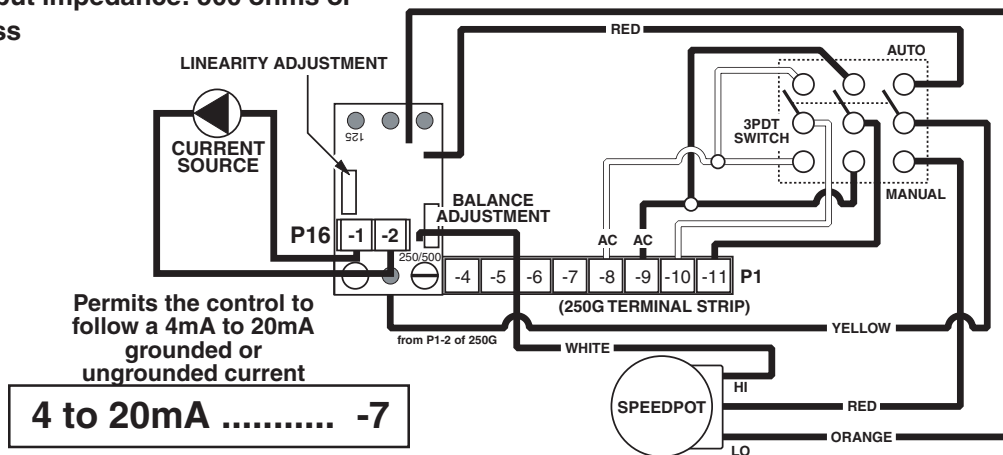

DO NOT USE TRIMPOT CHART TO ADJUST MIN AND MAX TRIMPOTS ON MAIN BOARD. IF ADJUSTMENT IS NEED THEN REFER TO THE SETUP PROCEDURE BELOW.

This option allows the control to be run in either the Manual mode via a speed pot or the Auto mode via the 4-20 ma. signal. The current signal input can be either grounded or ungrounded. The board sets on spacers screwed to terminals P1-1, P1-2, and P1-3 on the main board using long screws. The current source connects to the + and - two position terminal strip (P16-1 and -2) on the -7 option board.

This option includes a Balance trimpot which is used to scale the maximum speed in the manual mode. It is factory set so the maximum speed in manual equals the maximum speed in automatic.

The Linearity trimpot on the -7 option board is set at the factory for proper linearity, however this trimpot may need to be re-set after tuning the Max and Min trimpot settings on the control or if the Balance trimpot on the -7 must be reset for your specific application. If needed then refer to the setup procedure below.

Setting the Min, Max, Balance and Linearity Trimpots.

1. Preset the multi-turn Linearity trimpot and the Balance trimpot on the -7 option board full CW, set the Min trimpot full CCW and set the Max trimpot at about 50% rotation.
2. Input a 4 ma. current signal to the control and turn the Min trimpot CW to your desired minimum output voltage or to deadband (the point just before you begin to get an output).
3. Input a 20 ma. current signal to the control and set the Max trimpot to the desired maximum speed setting.
4. Switch the control to the Manual mode setting and adjust the Balance trimpot CCW as needed to attain your required manual mode maximum output speed. (Adjustable form 50 to 100% of maximum Auto mode setting)
5. Switch the control back to Auto mode. With 20 ma. still going to the control, turn the Linearity trimpot CCW until your output speed starts to decrease. Then slowly turn it back CW until you just reach your maximum speed setting.

*** Note:** This jumper wire is not used with some options. Consult factory if more than one option is being wired. Using the JU2 jumper wire when not required may cause permanent damage to the control.

-9 option

Special Cover Assembly

**Factory Installed Only
Enclosed Models Only**

NEMA 4/12 enclosure kit without cover mounted on-off switch and speedpot.

-11 option 10-Turn Speedpot

Field Installed Only
Chassis Models Only

Provides finer control of speed. Use standard hook-up directions and Trimpot Chart (page 7).

-17B option Acceleration Time Changes

Factory Installed Only
Available on all Models

Standard acceleration is variable from 0.5 to 8.0 seconds with the trimpot. The deceleration is between 0.06 and 0.8 seconds. This option extends the maximum acceleration so the range is between 0.8 and 20.0 seconds. Furthermore, this option has the deceleration time equal to the acceleration time, so deceleration range is also 0.8 to 20.0 seconds (depends on Accel setting, not an independent setting).

USE STANDARD HOOK-UP INSTRUCTIONS

-29 and -29B options Manual Reversing

-29 Enclosed Factory Installed Only
-29B Chassis *

Permits reversing of motor. This is accomplished using a 4PDT blocked center switch. When switched between the forward/reverse positions, a delay is encountered due to the blocked center position, which protects the control from any voltage that may be at the armature terminals. The center position is OFF/NEUTRAL.

THE MOTOR MUST COME TO A COMPLETE STOP BEFORE CHANGING DIRECTIONS. IF THE MOTOR DOES NOT COME TO A COMPLETE STOP, SERIOUS DAMAGE TO THE CONTROL MAY RESULT. BYPASS OF THE CENTER BLOCK OF THE SWITCH MAY RESULT IN DAMAGE TO THE CONTROL.

-29 (ENCLOSED VERSION) A 4PDT blocked center-off switch is factory installed into the cover assembly. The two position terminal strip (P3) is factory installed on the main board (below). The output on P3 is the switched (FWD/REV) output and the output of terminals P1-4 and P1-5 is not switched.

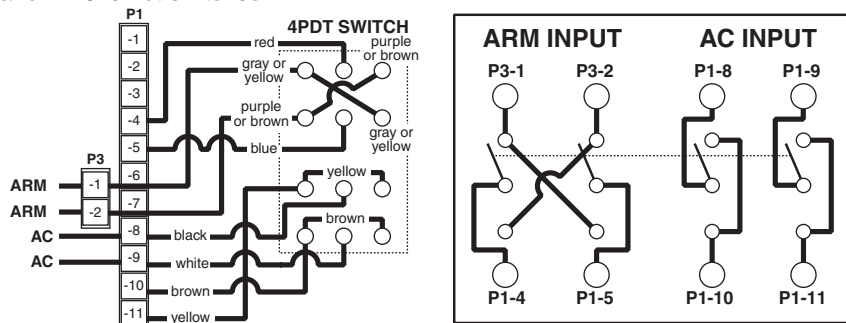

-29B (CHASSIS VERSION) * 250G control with a 4PDT switch (factory provided). The customer provides interconnecting wiring.

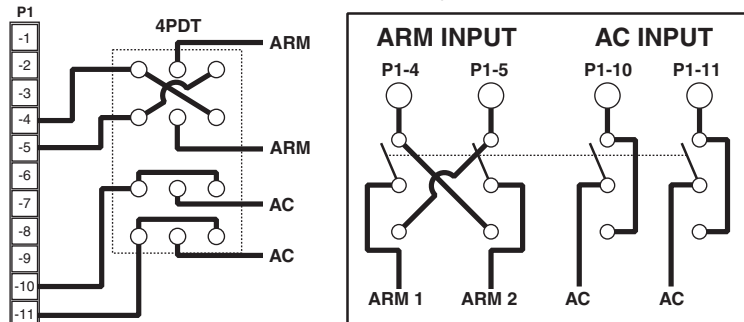

-34A option Torque Control

Factory Installed Only
Available Enclosed Only

The TORQUE (CURRENT LIMIT TRIMPOT) is controlled by the faceplate mounted potentiometer. Thus, the internally mounted MIN trimpot becomes the Speedpot. This speedpot may be moved to a remote location by removing the fixed resistors connected on P1-1 through P1-3, and installing a standard 5K 2W potentiometer.



DO NOT USE TRIMPOT SETTING CHART !

-55G2 and -56G2 options Isolated Voltage Input

Factory or Field Installed Chassis Version

-55G2 OPTION (CHASSIS)

This option permits use of either a grounded or non-grounded remote DC voltage speed command. This DC input range, which can be selected via the range jumper clip and adjusted with the GAIN trimpot, can range from 0-5VDC through 0-25VDC (P4-2 to P4-3) or 0-25VDC through 0-250VDC (P4-1 to P4-2). The output of this option board supplies a linear signal to the control. This signal is developed from the input voltage supplied to the option board. The option is powered by the dual voltage AC input and replaces the 5K speedpot.

INPUT IMPEDANCE:

1.2M ohm on high scale
150K ohm on low scale

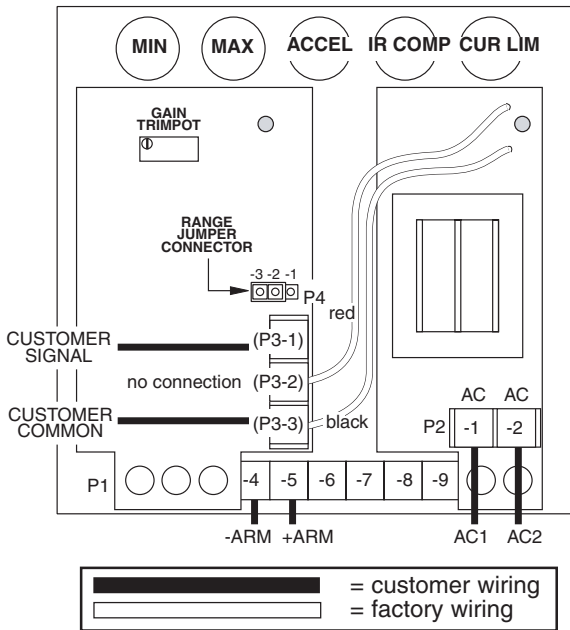

-56G2 OPTION (CHASSIS)

This is an Auto-Manual version of the -55G2 option. This option permits use of either a grounded or non-grounded remote DC voltage speed command. This DC input range, which can be selected via the range jumper clip and adjusted with the GAIN trimpot, can range from 0-5VDC through 0-25VDC (P4-2 to P4-3) or 0-25VDC through 0-250VDC (P4-1 to P4-2). The output of this option board supplies a linear signal to the control. This signal is developed from the input voltage supplied to the option board. The option is powered by the dual voltage AC input and replaces the 5K speedpot.

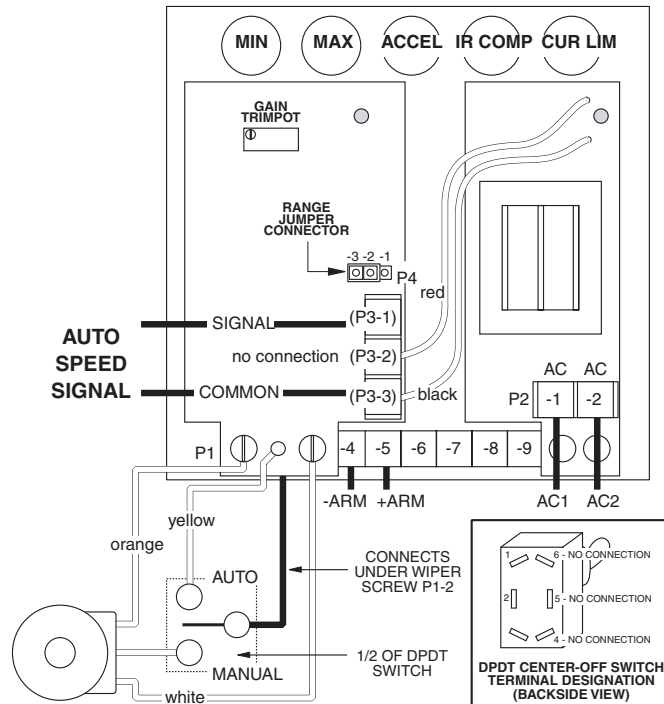

ADJUSTMENT PROCEDURE FOR -55G2 & -56G2 OPTIONS

1. With no power at the control, connect a DC voltmeter (meter must not be grounded) to control outputs as follows: **Meter COMMON to the -ARM terminal; Meter POSITIVE to the +ARM terminal.** Select correct meter range (0-90V or 0-180V).
2. Preset GAIN trimpot (option board) fully CCW, place range jumper clip in proper position.
3. Preset control as follows: MIN and I.R. COMP. fully CCW, MAX at 50%.
4. Apply desired AC voltage to control and option board.
5. With 0 volts into option board, adjust MIN trimpot on control to eliminate deadband. To do this, increase MIN fully CW, then adjust CCW until meter reads 0 volts.
6. Apply maximum input voltage to option board input.
7. Adjust GAIN until no further change in voltage output occurs and turn CCW until a 5V drop occurs, then set control MAX to 90VDC (180VDC for 240V input).
8. Set CURRENT LIMIT by using "TRIMPOT SETTING CHART" in the instruction manual.
9. For closed loop systems the I.R. COMP. should remain fully CCW. For open loop systems, set I.R. as per set-up procedure.
10. ACCEL/DECEL adjustments should be set as needed.

-56G2 option Isolated Voltage Input

Factory Installed Only Enclosed Version

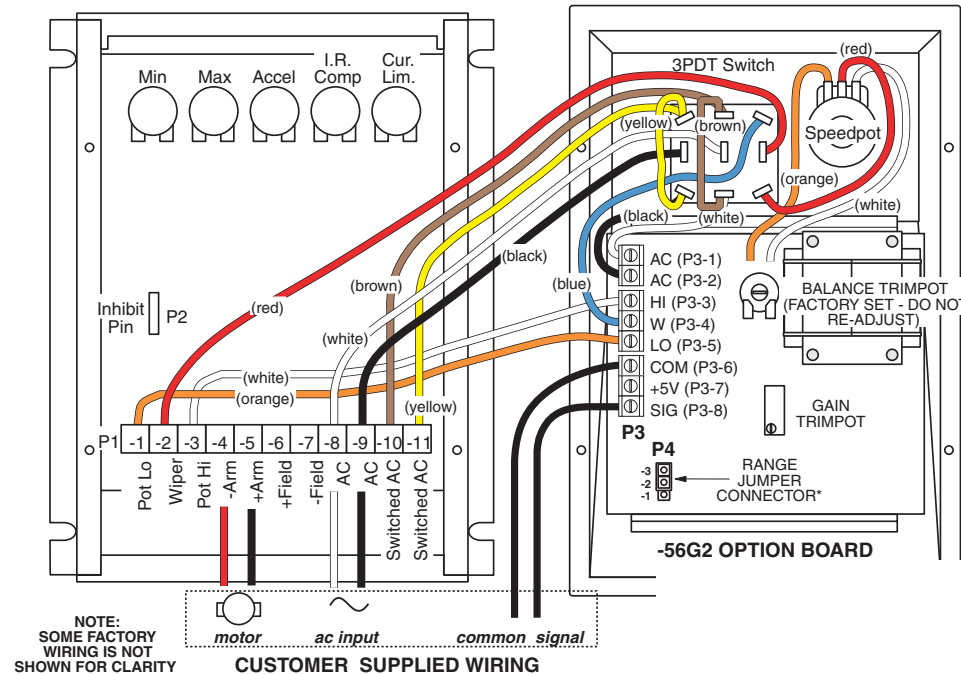

* Jumper clip is used to select input voltage range. When installed from P4-1 to P4-2, the range is 0-25VDC; when installed from P4-2 to P4-3, range is 0-5VDC through 0-25VDC.

See the following page for -55G2 and -56G2 Adjustment Procedures.

IN CASE OF DIFFICULTY

If a newly installed control will not operate, it is possible that a terminal or connection is loose. Check to make sure that all connections are secure and correct. If control still doesn't operate, refer to the following chart.

PROBLEM	POSSIBLE CAUSE(S)	CORRECTIVE ACTION(S)
Motor doesn't operate	<ul style="list-style-type: none"> - blown fuse - incorrect or no power source - speedpot set at zero - worn motor brushes 	<ul style="list-style-type: none"> replace fuse install proper service adjust speedpot CW to start replace motor brushes
Armature output voltage cannot be adjusted, output is a constant DC level	<ul style="list-style-type: none"> - no motor or load connected - speedpot low connection open 	<ul style="list-style-type: none"> check that motor or load is connected to armature terminals check that speedpot low wire is connected
Motor stalls, or runs very slowly with speedpot turned fully CW	<ul style="list-style-type: none"> - low voltage - overload condition - worn motor brushes - max speed set incorrectly 	<ul style="list-style-type: none"> check - should be above 108V reduce load replace motor brushes see ADJUSTMENT PROCEDURE
Motor hunts	<ul style="list-style-type: none"> - too much I.R. Comp. - motor is in current limit - motor not pulling enough current - max trimpot set too high - motor speed is above rated speed 	<ul style="list-style-type: none"> see ADJUSTMENT PROCEDURE see ADJUSTMENT PROCEDURE current must be greater than 150 mA D.C. see ADJUSTMENT PROCEDURE reduce speed
Repeated fuse blowing	<ul style="list-style-type: none"> - low voltage - overload condition - worn motor brushes - defective motor bearings - defective electrical component 	<ul style="list-style-type: none"> check - should be above 108V reduce load replace replace call Dart Distributor or Representative
Motor runs but will not stop	<ul style="list-style-type: none"> - incorrect wiring (enclosed version) - defective wiring - defective component 	<ul style="list-style-type: none"> check TERMINAL STRIP WIRING for correct wiring instructions (note AC line connection in particular) check wiring call Dart Distributor or Representative

If control still will not operate, consult your Dart Distributor or Representative.

SPECIFICATIONS

AC input voltage ±10% of rated line voltage
 Acceleration 0.5 to 8.0 seconds (note -17B option)
 Amps - DC output 150 mA to 10.8 Amps D.C.
 Controller overload capacity 150% for one minute
 Current limit tripoint range 0.3 to 3.0 Amps D.C. (251G); 1.0 to 15.0 Amps D.C. (253G)
 Deceleration (dependent on acceleration time setting)06 to .80 second range
 Dimensions and weight:

	WIDTH	LENGTH	HEIGHT	WEIGHT	TYPE
ENGLISH	5.53"	7.25"	3.50"	25.50 oz.	enclosed chassis
	5.53"	7.00"	1.55"	16.25 oz.	
METRIC	140mm	184mm	89mm	723 grams	enclosed chassis
	140mm	178mm	39mm	413 grams	

Drive service factor 1.0
 Efficiency 85% typical
 Input frequency 50 or 60 Hertz
 Max. tripoint speed range 66% to 110% of base speed
 Min. tripoint speed range 0% to 30% of maximum speed
 Minimum external impedance (pot hi to pot low) 5K ohms
 Power devices packaged full wave bridge
 Shunt field voltage 100VDC for 120VAC input; 200VDC for 240VAC input; 1 amp maximum
 Speed control via 5K ohms 2W linear potentiometer or 0-10VDC isolated signal
 Speed range 50:1
 Speed regulation ±1% of base speed
 Temperature range -10° to 45° C. ambient (15° to 115° F.)
 Transient protection G-Mov
 Type ramp of accel/decel linear

TYPICAL MOTOR CURRENTS

Horsepower	1/50	1/20	1/8	1/4	1/3	1/2	3/4	1.0	1.5	2.0
Typical AC Amps (120VAC)	0.26	.70	1.80	3.50	4.40	6.50	9.30	13.20	-----	-----
Typical Arm Amps (120VAC)	0.20	.50	1.40	2.70	3.40	5.00	7.20	10.20	-----	-----
Typical AC Amps (240VAC)	-----	-----	-----	1.80	2.20	3.30	4.80	6.50	9.70	12.90
Typical Arm Amps (240VAC)	-----	-----	-----	1.40	1.70	2.50	3.70	5.00	7.50	9.90

250G SERIES PARTS PLACEMENT & LIST

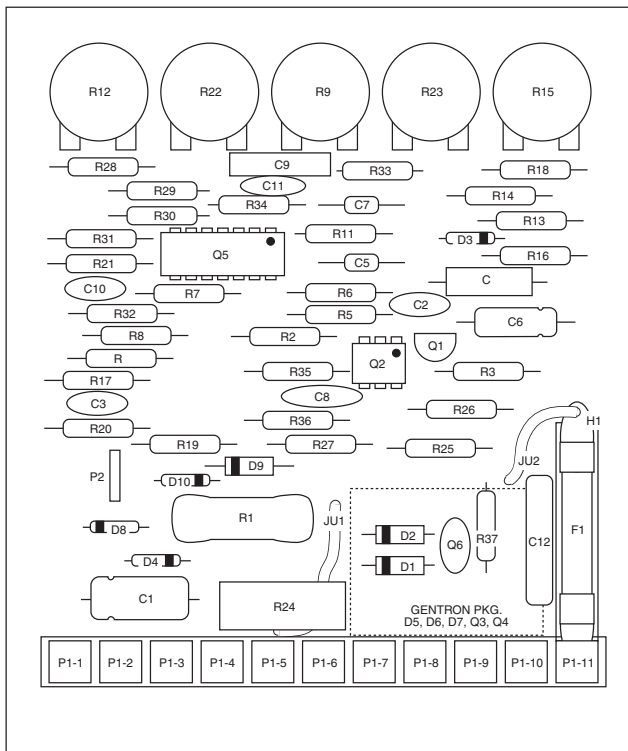

NOTE: ALL RESISTORS 1/2W UNLESS SPECIFIED
 * CUSTOMER WIRED SPEEDPOT

RESISTORS

- | | | | |
|-----|--------------|-----|-------------|
| R1 | 15K 8W | R20 | 1K |
| R2 | 2.7K | R21 | 1K |
| R3 | 2.7K | R22 | 50K (MAX) |
| R4 | 1.2M | R23 | 100Ω (I.R.) |
| R5 | 180K | R24 | .01Ω 5W |
| R6 | 82K | R25 | 390Ω |
| R7 | 470K | R26 | 390Ω |
| R8 | 15K | R27 | 1K |
| R9 | 250K (ACCEL) | R28 | 20K 1/4W |
| R10 | 5K SPEEDPOT* | R29 | 10K |
| R11 | 10K | R30 | 180K |
| R12 | 5K (MIN) | R31 | 390K |
| R13 | 470K | R32 | 47K |
| R14 | 300K | R33 | 470K |
| R15 | 5K (C.L.) | R34 | 100K |
| R16 | 4.7K | R35 | 470Ω |
| R17 | 390K | R36 | 91K |
| R18 | 4.7K | R37 | 1Ω |
| R19 | 150K | | |

-17B CHANGES:

C9 ... 2.2uf 50V N.P.
 R28 .. 10K

-34A CHANGES:

R10... Connect to 3 wires
 from R15 position
 R15 .. Delete tripoint

251G-12C CHANGES:

R241& 5W

CAPACITORS

- | | |
|-----|-------------|
| C1 | 10uf 35V |
| C2 | .01uf 100V |
| C3 | .001uf 1KV |
| C4 | .033uf 400V |
| C5 | .1uf 50V |
| C6 | 22uf 16V |
| C7 | .1uf 50V |
| C8 | .0047uf 1KV |
| C9 | .22uf 250V |
| C10 | .01uf 100V |
| C11 | .01uf 100V |
| C12 | .068uf 250V |
- (across-the-line)

DIODE

- | | |
|-----|-----------|
| D1 | 1N4005 |
| D2 | 1N4005 |
| D3 | 1N914B |
| D4 | 1N5242B |
| D5 | L512FY131 |
| D6 | L512FY131 |
| D7 | L512FY131 |
| D8 | 1N914B |
| D9 | 1N4005 |
| D10 | 1N5233B |

ACTIVE DEVICES

- | | |
|----|------------|
| Q1 | 2N6027 |
| Q2 | 3052 MOC |
| Q3 | L512FY131 |
| Q4 | L512FY131 |
| Q5 | LM324N IC |
| Q6 | 275V G-MOV |

MISC. PARTS

- | | |
|-----|---|
| F1 | 10 AMP FUSE (Bussman ABC or Little Fuse 314 Series ceramic fuses) |
| H1 | S-8201-1X FUSE HOLDER |
| JU1 | 1.75" - 16GA. SOLID INS. WIRE |
| JU2 | 2.50" - 16GA. SOLID INS. WIRE |
| P1 | 11 POS. TERMINAL STRIP |
| P2 | 1/4" SPADE PIN TERMINAL |

250G SERIES SCHEMATIC

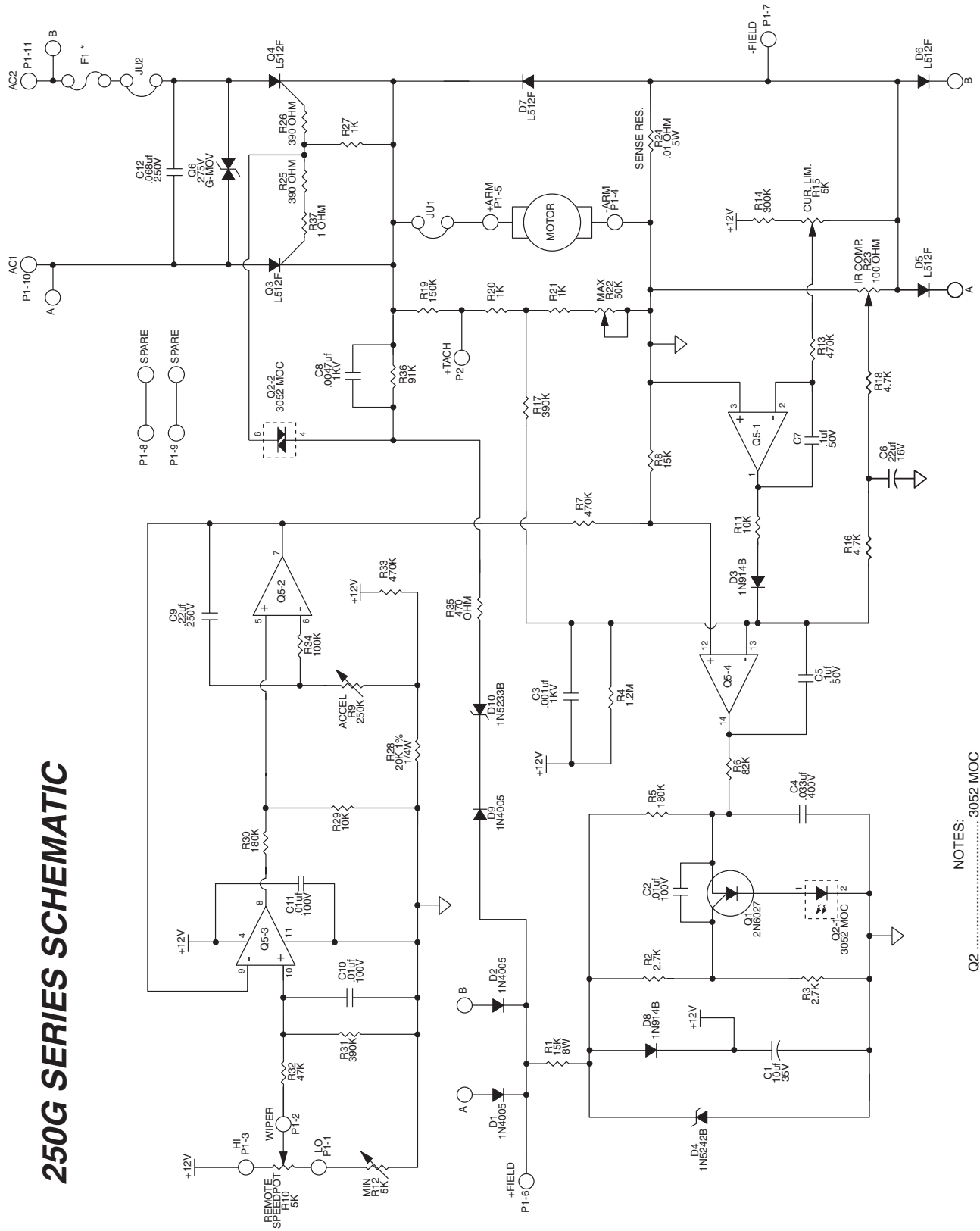

NOTES:
 O2 3052 MOC
 O3, O4, D5, D6, D7 L512FV131 GENTRON
 O6 LM324NLC
 F1 BUSS ABC-10 or LITTLEFUSE 314010
 ALL RESISTORS 1/2W UNLESS NOTED OTHERWISE

REPAIR PROCEDURE

In the event that a Product manufactured by Dart Controls Incorporated (DCI) is in need of repair service, it should be shipped, freight paid, to: Dart Controls, Inc., 5000 W. 106th Street, Zionsville, IN. 46077, ATTN: Repair Department.

Those orders received from anyone without an existing account with DCI will need to specify if they will be paying COD or Credit Card (Master Card or Visa). This information is required before work can begin. If you have an account with Dart your order will be processed according to the terms listed on your account.

Completed repairs are returned with a Repair Report that states the problem with the control and the possible cause. Repair orders are returned via UPS Ground unless other arrangements are made. If you have further questions regarding repair procedures, contact your Dart Controls, Inc. at 317-733-2133 Ext.460.

YOUR MOTION SYSTEMS SOLUTION PROVIDER



125D SERIES
AC INPUT - VARIABLE DC OUTPUT
1/50 HP through 1.0 HP



250G SERIES
AC INPUT - VARIABLE DC OUTPUT
1/50 HP through 2.0 HP



65 SERIES
DC INPUT - VARIABLE DC OUTPUT
CURRENT RATINGS OF 20, 40, AND
60 AMPS



700/COMMUTROL SERIES
DC BRUSHLESS
5 & 20 Amp for
12,24,& 36VDC Inputs



MDP SERIES
PROGRAMMABLE
CLOSED LOOP DC
SPEED CONTROL



DM SERIES
FIELD PROGRAMMABLE
DIGITAL TACHOMETER

Dart Controls, Inc. is a designer, manufacturer, and marketer of analog and digital electronic variable speed drives, controls, and accessories for AC, DC, and DC brushless motor applications.

Shown above is just a sampling of the expanded line of Dart controls that feature the latest in electronic technology and engineering. Products are manufactured in the U.S.A. at our Zionsville (Indianapolis,

Indiana) production and headquarters facility - with over 2,000,000 variable speed units in the field.

In addition to the standard off-the-shelf products, you can select from a wide variety of options to customize controls for your specific application. For further information and application assistance, contact your local Dart sales representative, stocking distributor, or Dart Controls, Inc.

Dart Controls, Inc.

Manufacturer of high quality DC and AC motor speed controls and accessories since 1963.

P.O. Box 10
5000 W. 106th Street
Zionsville, Indiana 46077
Phone: (317) 733-2133
Fax: (317) 873-1105