

Vehicle Sensors

90250

PINCH FORCE SENSOR

Model 90250, Window/Sunroof Pinch Force Sensor Kit, is used to measure pinch force of automatically closing windows, doors, and sunroof systems. It includes four sensors, the PMAC 2000 portable readout instrument, and hard shell carrying case. The hand held units measure and record the closing force of a power window or sunroof. The sensors have a tuned stiffness and were designed to help automakers and OEM's comply with FMVSS 118 (Federal Motor Vehicle Safety Standard section 571, title 49).

The instrument and sensors are Auto-ID enabled allowing self-calibration with no operator intervention.

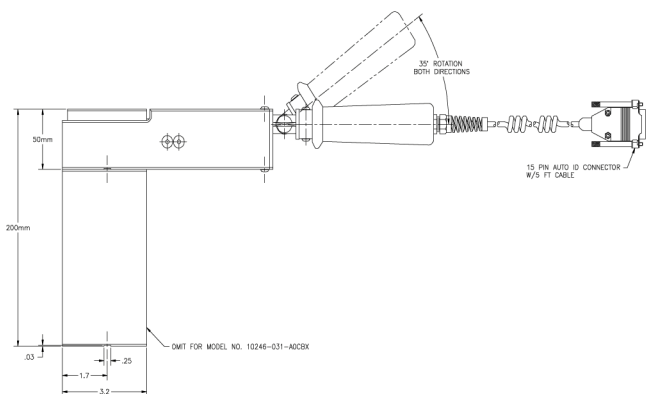
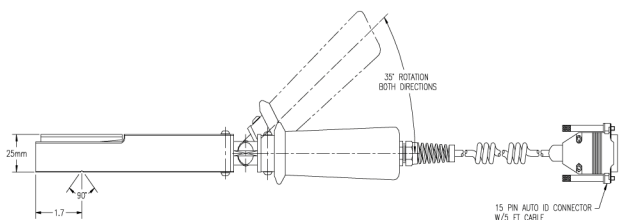
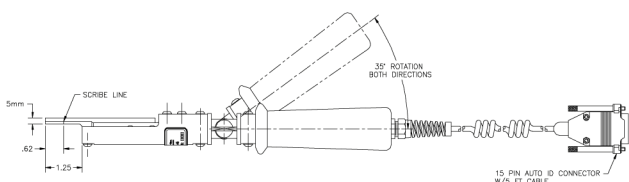

FEATURES

- Field tested
- Easy to use
- Peak recording feature
- Auto-ID feature
- Battery pack included

KIT INCLUDES ALL FOUR SIZES REQUIRED BY FMVSS

- 5 mm @ 65 N/mm stiffness (Model 10246-031-A0C00)*
- 25 mm @ 65 N/mm stiffness (Model 10246-031-A0000)*
- 50 mm @ 20 N/mm stiffness (Model 10246-031-A0A00)*
- 200 mm @ 20 N/mm stiffness (Model 10246-031-AB00)*
- PMAC 2000 instrument (Model 90222)
- Mar proof contact surfaces on larger units

*Each sensor is overload protected to 300% F.S.

OPTIONS

- 500N FS capacity wand with 100mm @ 20N/mm stiffness (Model 10246-012-AOEBA).

