

SPECTROTILT IItm – Dual Axis Inclinometers

The SPECTROTILTtm II family of Dual Axis Inclinometers combine the SP 5000 Series sensor with CMOS or custom designed hybrid signal conditioning circuitry. The result is a high performance / low cost dual axis inclinometer which can tackle the most demanding applications. All models are temperature compensated to the full industrial range, and feature null and scale adjustments (factory set). The open architecture construction makes them ideal for OEM applications, and for easy installation into custom enclosures. An optional flame retardant, molded ABS plastic enclosure is available for the SSY0090P and SSY0091P models (*see note below).

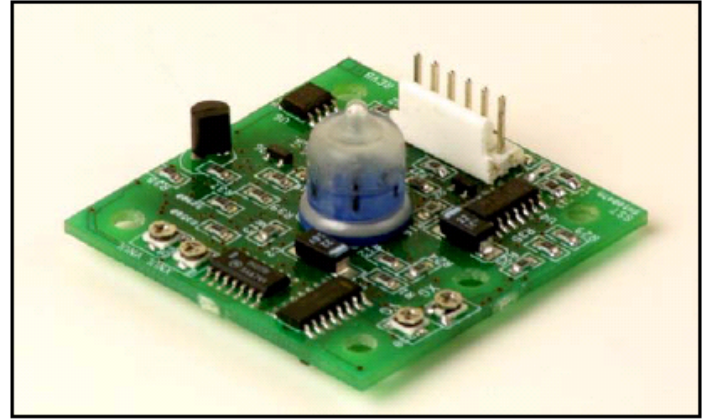

Model #SSY0091P shown above

Specifications

Characteristic	Model					
	SSY0090	SSY0091	SSY0090C	SSY0091C	SSY0090P	SSY0091P
Range (arc degrees)	+/-45	+/-20	+/-45	+/-20	+/-45	+/-20
Output (Vdc, referenced to input common)	+/-7	+/-7	+1 to +4	+1 to +4	+1 to +4	+1 to +4
Input Voltage (Vdc, unregulated)	+/-11 to +/-16	+/-11 to +/-16	+5, +/-5%	+5, +/-5%	+4.85 to +16	+4.85 to +16
Input Current (mA)	12	12	1.5	1.5	1	1
Resolution (arc degrees)	0.02	0.005	0.01	0.01	0.01	0.01
Repeatability (arc degrees)	0.01	0.01	0.01	0.01	0.01	0.01
Output Ripple						
% of signal value	0.2	0.2	0.2	0.2	-	-
mV RMS	-	-	-	-	0.5	0.5
Accuracy (arc degrees)						
at 10 degrees	-	+/-0.06	-	+/-0.06	-	+/-0.06
at 20 degrees	-	+/-0.6	-	+/-0.6	-	+/-0.6
at 30 degrees	+/-2	-	+/-2	-	+/-1	-
at 45 degrees	+/-5	-	+/-5	-	+/-5	-
Settling Time (mSec @ 20 degrees C)	500					
Temperature Range (degrees C)						
Operating	-20 to +70					
Storage	-40 to +80					
Temp. Coefficient of Null (arc seconds / deg.C)	20	10	20	10	20	20
Temp. Coefficient of Scale (5/deg.C typ.)	0.1	0.1	0.1	0.1	0.1	0.1
Null Adjustment Range	+/-1	+/-1	+/-0.2	+/-0.2	+/-0.2	+/-0.2
Weight (grams/approx.)	36	34	36	34	15	15

*Note: Part numbers for available models with ABS plastic housing are as follows.

• SSY0090P w/housing = p/n SSY0194

• SSY0091P w/housing = p/n SSY0195

SPECTROTILT IItm – Dual Axis Inclinometers

Dimensions, Electrical Connections, and Adjustments

SSY0090 and SSY0091

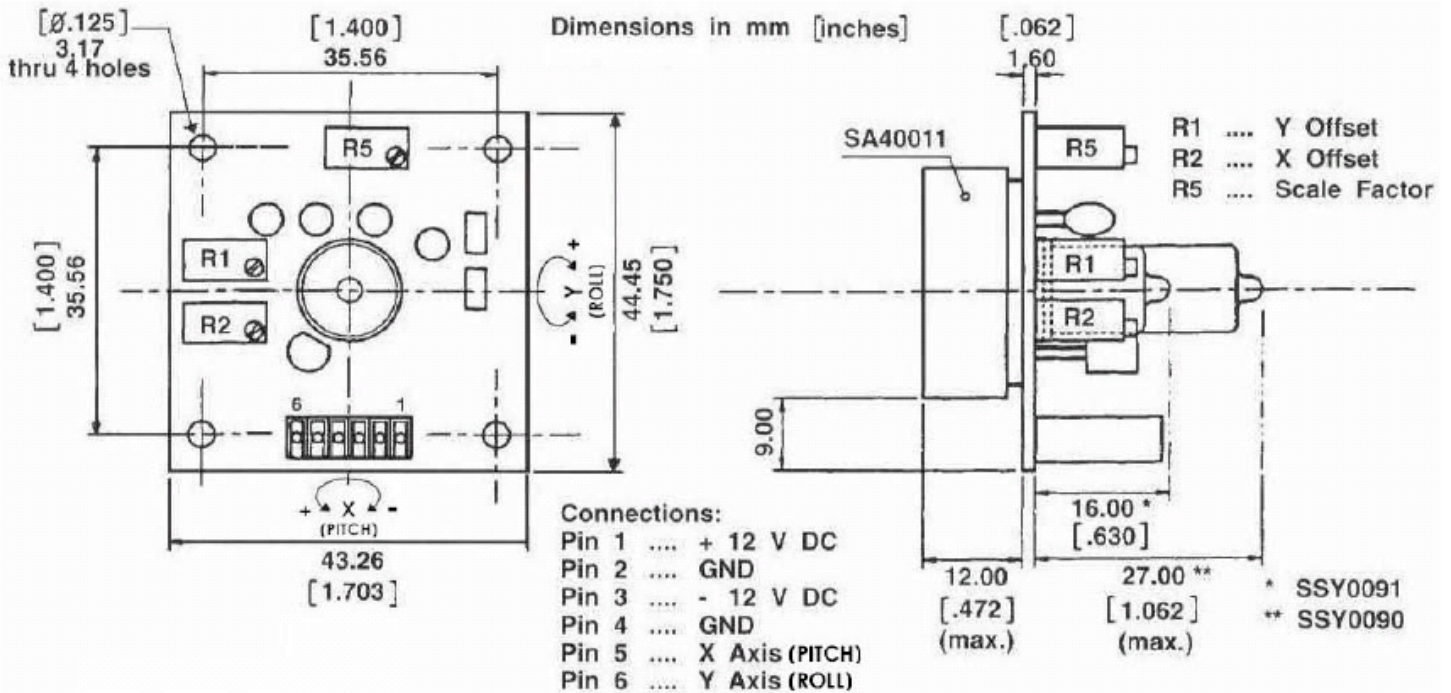

SSY0090C and SSY0091C

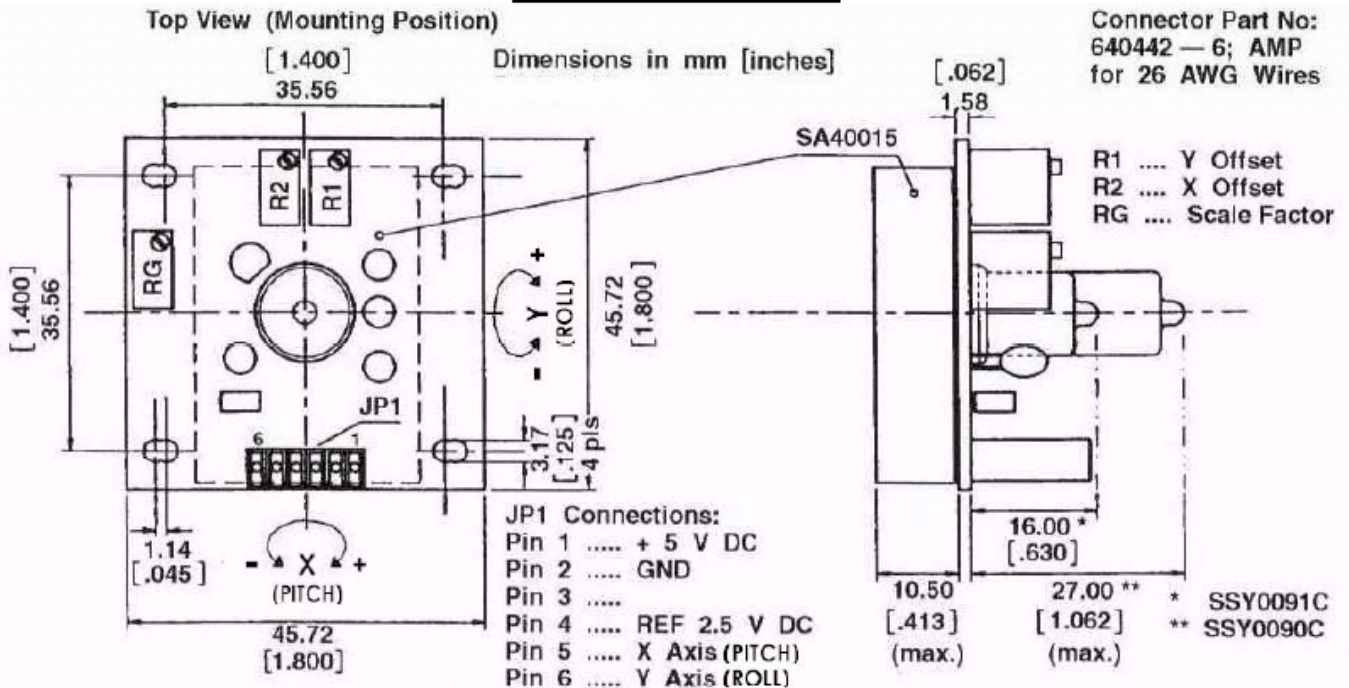

SPECTROTILT IItm – Dual Axis Inclinometers

SSY0090P and SSY0091P

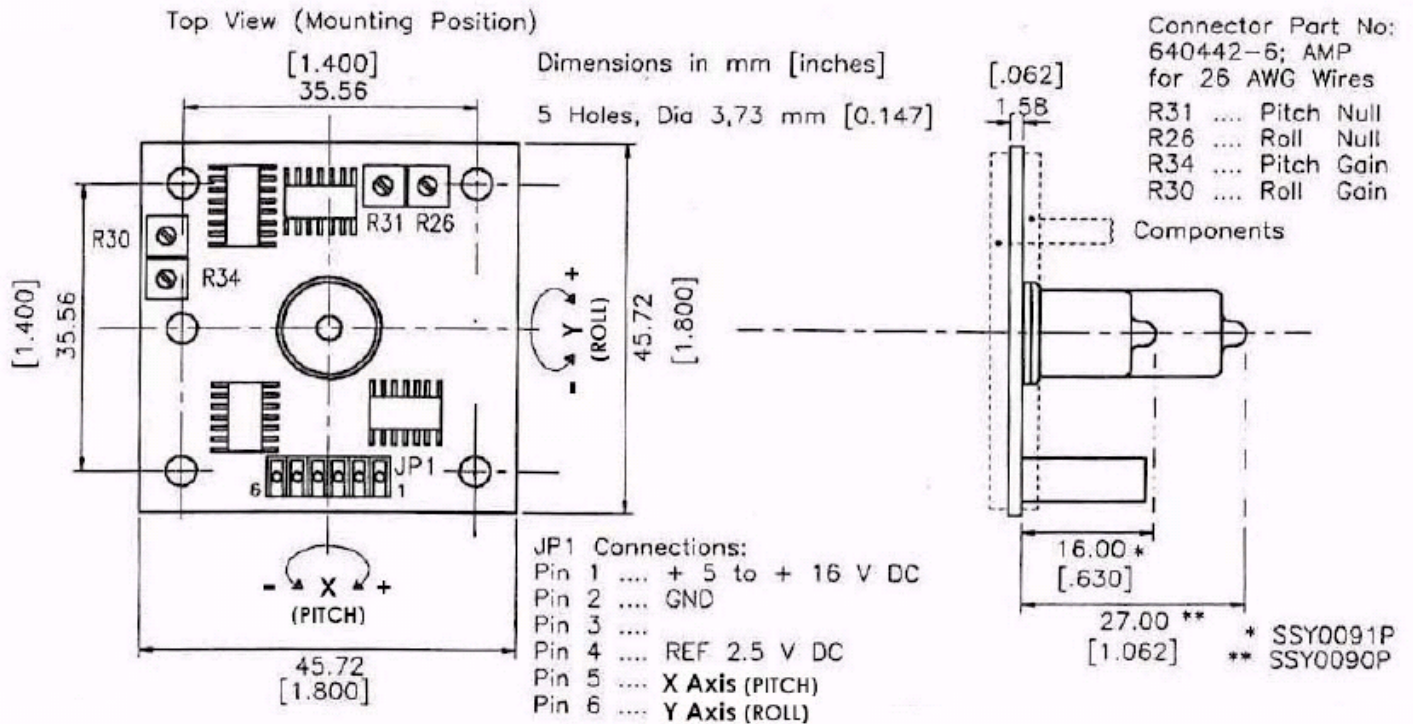

ABS Plastic Housing version

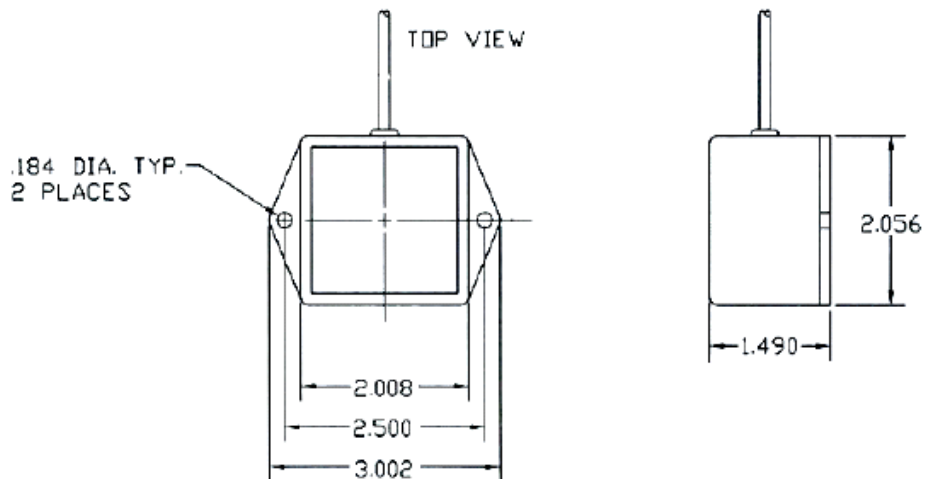

• SSY0090P w/housing = p/n SSY0194

• SSY0091P w/housing = p/n SSY0195