

# SIS 3 Contacts

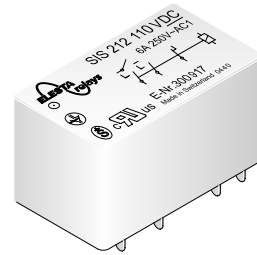

## Relay data

- PCB relay with forcibly guided contacts
- Protective separation between control and load circuit (leakage and creepage distance > 8mm)
- EN 50205, type A
- Double and reinforced insulation between the contacts
- Contact mounting: SIS212 2NO/1NC
- Small external dimensions
- Mean coil power 0,6W

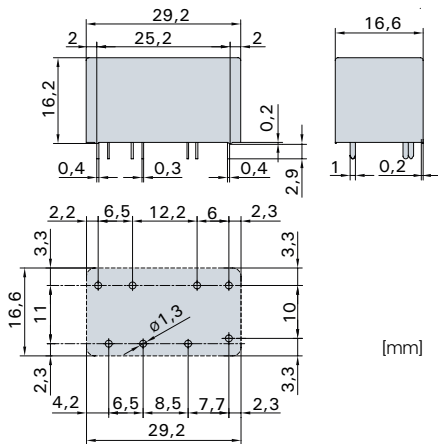

Contact material	AgCuNi+0,2-0,4µm Au
Type of contact	Single contact
Rated switching capacity	250VAC 6A AC1 1'500VA
Electr. life AC1 (360 cycles/h)	approx. 100'000
Inrush current max.	30A for 20ms
Switching voltage range	5 to 440VDC/VAC
Switching current range*	5mA to 6A
Switching capacity range*	60mW to 1'500W (VA)
Contact resistance (as delivered)	≤ 100mΩ

\* Guide values

### Standard coils for direct current (other voltages on request)

Nominal voltage VDC	Min. pick-up voltage at 20°C	Drop-out voltage at 20 °C	Nominal current in mA	Resistance in Ohm at 20 °C	Tolerance in %
5	≤ 3,5	≥ 0,5	120,0	41,5	± 10
9	≤ 6,3	≥ 0,9	66,6	135	± 10
12	≤ 8,4	≥ 1,2	50,0	240	± 10
18	≤ 12,6	≥ 1,8	33,3	540	± 10
24	≤ 16,8	≥ 2,4	25,0	960	± 10
48	≤ 33,6	≥ 4,8	12,5	3'840	± 10
60	≤ 42,0	≥ 6,0	10,0	6'000	± 13
110	≤ 77,0	≥ 11,0	5,4	20'150	± 15

### Ordering example

**SIS 2 1 2 . S ZGR009** Wash-resistant, RT III  
Special design / sensitive coil  
Coil voltage  
Soldering tags  
Number of NC contacts  
Number of NO contacts  
Type designation

## General data

### Circuit diagram (view on relay upper side)

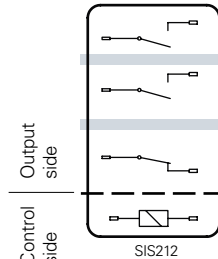

- - - Basic insulation
- ▬ Double or reinforced insulation

Mechanical life	> 10 x 10 <sup>6</sup> operations
Switching frequency, mechanical	15Hz
Response time (all NO closed)	typically 10ms
Drop-out time** (all NC closed)	typically 3ms
Bounce time of NO contact	typically 2ms
Bounce time of NC contact	typically 15ms
Shock resistance 16ms	NO contact 30g NC contact 10g
Vibration resistance 10-200Hz	NO contact 20g NC contact 5g
Test voltage coil/control contact	2'500Veff 1min
Test voltage output contacts as against each other	4'000Veff 1min
Test voltage contact open	1'500Veff 1min
Insulation resistance at Up 500V	10 <sup>8</sup> Ω
Creeping resistance	CTI 175
Weight	approx. 20g
Mounting position	any
Ambient temperature	-40°C to +70°C
Type of protection	RT II / RT III optionally
Solder bath temperature	270°C/5s
Thermal resistance	55K/W
Temperature limit for coil	120°C
Pollution degree	3
Overvoltage category	III
Resistance to short circuiting	1'000A SCPD 6A gG (pre-fuse)

\*\* without spark suppression

### Insulation terms

Coil to control contacts:	Basic insulation
Coil/control contacts to output contacts:	Double or reinforced insulation > 8mm

### Tests, regulations

Approvals	SEV, UL, cUL, TÜV
Insulation class	VDE 0110 / group C 250VAC
Protection class II	VDE 0106
Fire protection requirements	UL 94 / V0

## Diagrammes

### Contact lifetime

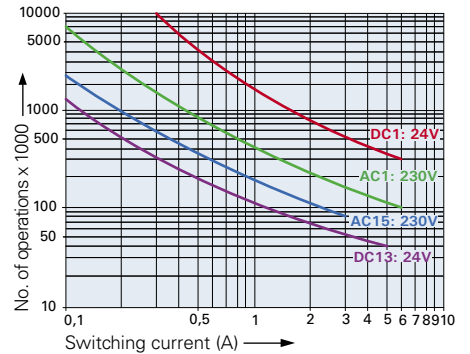

Max. switching characteristics (determined acc. to DIN EN 60947-4-1 / EN 60947-5-1):

- AC 1: 250V/6A
- AC 15: 230V/3A
- DC 1: 24V/6A
- DC 13: 24V/5A/0,1 Hz
- UL 508: B300 / R300

Maximal contact load at AC 1 with 230V:  
2 contacts each with 6A

### Load limit curve with direct current

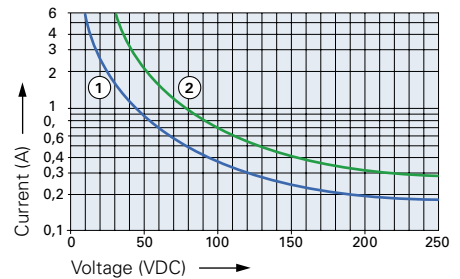

- 1) Inductive load, L/R 40 ms
- 2) Resistive load

### Excitation voltage range

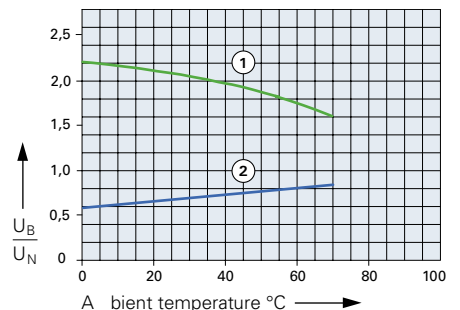

- 1) Max. excitation voltage with contact load ≤ 2A
- 2) Min. excitation voltage (guaranteed values) without previous operation

No heat accumulation due to intrinsic heating of other components.  
Continuous duty 100%.



**American Electronic Components, Inc.**

1101 Lafayette Street, Elkhart, IN 46516, Tel: (574) 295-6330, Fax: (574) 293-8013, [sales@aecsensors.com](mailto:sales@aecsensors.com)