

Dart's VSI Voltage Signal Isolator Series Features

The Dart VSI (voltage signal isolator) permits the user to control the output of a variable speed drive with a grounded or ungrounded DC input signal. The range of this input signal can be field selected for a range of 0-5 through 0-25 or 0-25 through 0-250VDC. The input impedance of these ranges is 150K Ω and 1.2M Ω , respectively. The GAIN trimpot is used to adjust the output of the VSI to full on when a full speed signal is applied to its input terminals. The VSI incorporates Dart's patented feedback circuit, which virtually eliminates output changes due to the thermal drift of logic components. The VSI is packaged in an aluminum chassis mount housing and contains an on-board power supply for its logic circuit, which is powered from 120 VAC or 240 VAC line power. An electrical isolation rating of 2500Vrms is achieved by the use of an optically isolated IC package. The VSI requires an AC input to drive the power supply and is available in two variations.

Although this isolator was specifically designed to be used with Dart's 500/530B series, it can be used with virtually any speed control that has a speed reference circuit of +5 to +15VDC and an input impedance greater than 47K Ω . The output of the VSI is a filtered, pulse width modulated signal that is directly proportional to the input speed signal. The wide input range allows the VSI to follow signals as low as +5V logic levels and up to the 180VDC levels present at the armature leads of a 180VDC motor. By simply connecting the input terminals across the armature leads of a "master motor", you can use the VSI for master/follower operation. The addition of a scaling pot will provide for proportional follower operation.

Hook-up Diagram

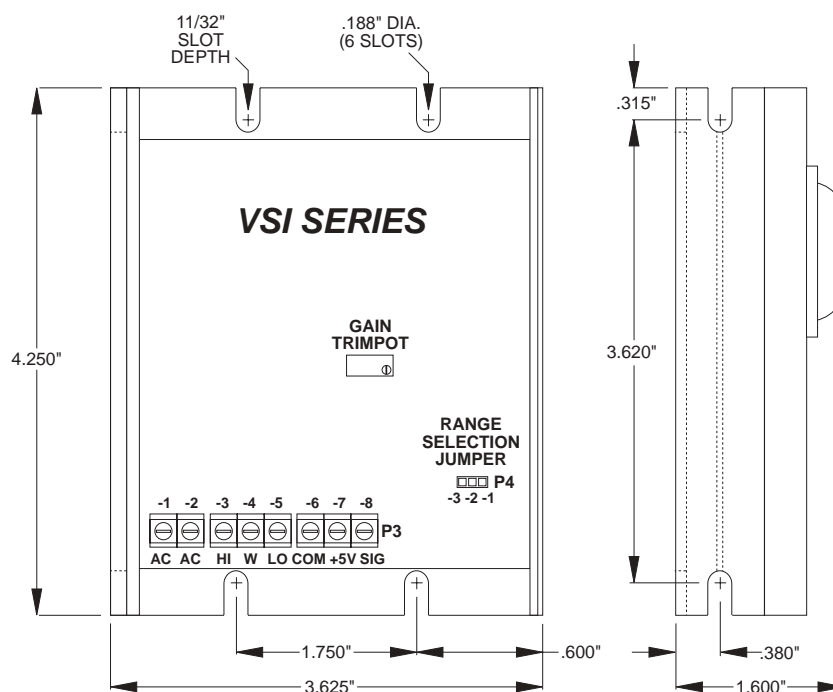

Setup Procedures

1. With no power to VSI or speed control, connect a DC voltmeter (meter must not be grounded) to the speed control output as follows: meter COMMON to the -ARM terminal and meter POSITIVE to the +ARM terminal. Select the correct meter range based upon the armature voltage level.
2. Install the jumper clip for the proper input voltage range (see description on the hook-up page) and preset the gain trimpot fully CCW.
3. Preset speed control trimpots: MIN, MAX, I.R. COMP fully CCW and CL fully CW.
4. Apply AC input of correct voltage to the speed control and the VSI.
5. With 0VDC into the VSI, adjust MIN to the desired setting.
6. Apply maximum input voltage to the VSI. The motor will begin to rotate.
7. Turn the GAIN trimpot CW until no further change in the output voltage occurs, then turn CCW one turn, then set the max trimpot to desired setting.
8. Set Current Limit per speed control instructions.
9. For closed loop systems, the I.R. COMP should remain CCW. For open loop systems, set I.R. COMP as needed.

VSI HOOK-UP CONFIGURATIONS

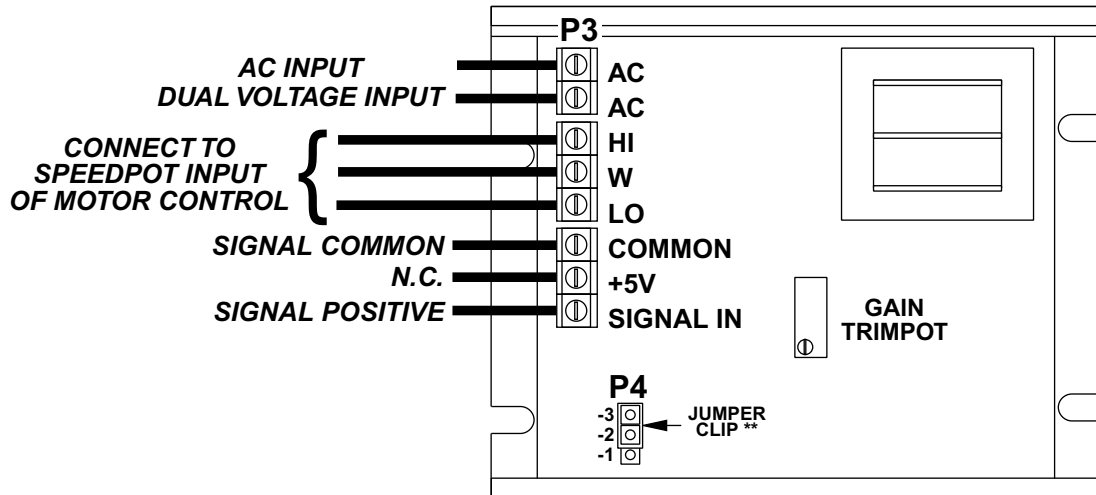

STANDARD HOOK-UP

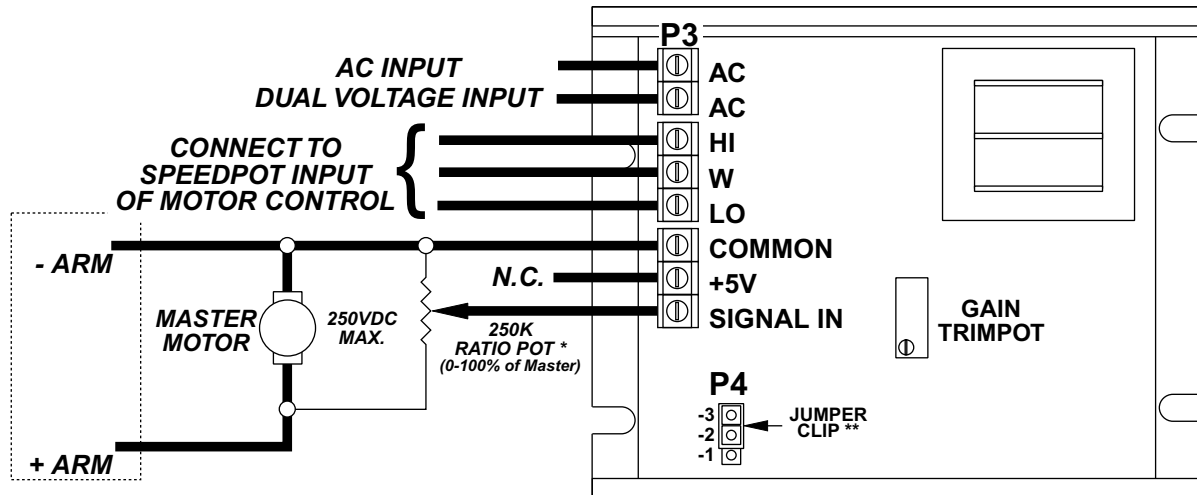

FOLLOWER MODE HOOK-UP

NOTES:

- * If ratio of Master is NOT needed, delete the 250K pot and connect +Armature directly to Signal Input.
- ** Jumper clip is used to select input voltage range. When installed from P4-1 to P4-2, the range is 0-25VDC thru 0-250VDC; when installed from P4-2 to P4-3, range is 0-5VDC thru 0-25VDC.

DART CONTROLS, INC.
 5000 W. 106th STREET ZIONSVILLE INDIANA 46077

TITLE: **VSI HOOK-UP CONFIGURATIONS - DART LITERATURE # LTVSIHU (SIDE 2 OF 2)**

DWN: **GMM** REF. DWG. NO. CUST:

SCALE: MAT'L: FINISH:

RELEASE DATE: **3-25-91** REV. DATE: **6-30-97** DWG. NO. **A-1-2154C**

PRN # 693	REVISIONS		UNLESS OTHERWISE SPECIFIED: DIMENSIONS ARE IN INCHES	
ECN NO. 1149	DATE: 3-15-91	DESC: INTRODUCTION	TOLERANCES DECIMALS ANGULAR .XXX ± .025 ±	
ECN NO. 1264	DATE: 4-20-92	DESC: PC LAYOUT CHG.		
ECN NO. -----	DATE: 10-03-95	DESC: ADD LT NUMBER	DO NOT SCALE DRAWING	
ECN NO.	DATE:	DESC:		
ECN NO.	DATE:	DESC:		