

Encoder WDG 58B



- Clamping flange
 - Rugged industrial standard encoder
 - Protection to IP67, shaft sealed to IP65
 - Maximum mechanical and electrical safety
 - With control output
 - Optional: -40°C ... +80°C
- www.wachendorff.de/wdg58b-engl

Application field

Electric motors, machine tools, weigh scales, conveyors, printing machines, drives, textile machines, production lines, injection-moulding machines, test machines, elevators/lifts, doors and gates.

Available PPR up to 5000

Mechanical Data

Housing

- Clamping flange: Aluminium
- Housing: Aluminium, powder coated
- Cam mounting: pitch \varnothing 69 mm

Shaft

- Material: stainless steel
- Load on shaft end: max. 220 N radial, max. 120 N axial
- Starting torque: approx. 1 Ncm at ambient temperature

Bearings

- Type: 2 precision ball bearings
- Service life: 10^9 revs. at 100% of full rated shaft load, 10^{10} revs. at 40%, 10^{11} revs. at 20%

Operating speed: 8.000 rpm

Weight: approx. 250 g

Connections: Shielded cable or connector

Protection rating: IP67, shaft sealed to IP65 (EN 60529)

Operating temperature: -20... +80°C, 1Vss: -10... +70°C

Storage temperature: -30... +80°C

Electrical Data

Power supply	Output circuit	Key	Output circuit*	Key
10-30 VDC	HTL	G24	HTL, inv.	I24
5 VDC	TTL	G05	RS422, TTL comp.	I05
5-30 VDC	HTL	H30	HTL, inv.	R30
10-30 VDC	-	-	RS422, TTL comp.	245
5 VDC	-	-	1 Vss Sin./Cos.	SIN

*Only for cable or connector:

K2, L2, K3, L3, S4, S5, SB8, SC8, SB12, SC12

Cable connection

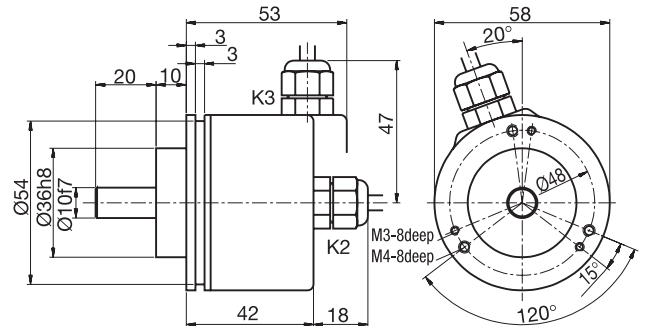

Connector S2, S3, 7-pin

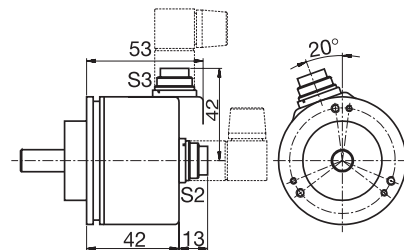

Connector S4, S5, 12-pin

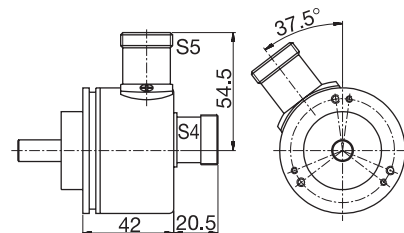

MIL-connector S6, 6-pin

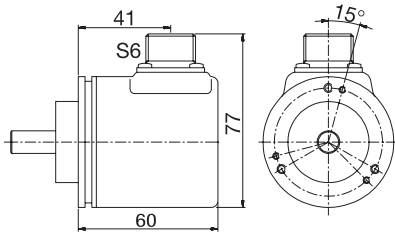

Valve-connector S7, 4-pin

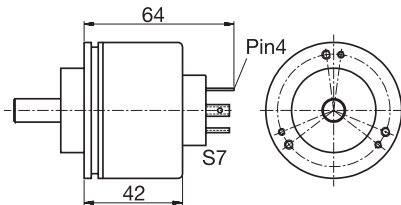

Sensor-connector (M12x1) SB, SC, 4-, 5-, 8-, 12-pin

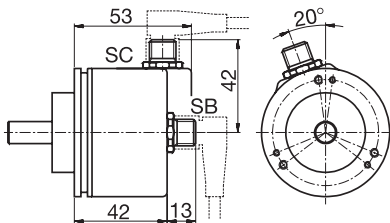

All dimensional specifications in mm.
 Further technical information on www.wachendorff.de/gtd
 Matching accessories on www.wachendorff.de/acs

Ordering information:

Output circuit: G24 = 10-30 VDC, HTL G05 = 5 VDC, TTL H30 = 5-30 VDC, HTL	Output circuit inv.: I24 = 10-30 VDC, HTL I05 = 5 VDC, RS422 TTL comp. R30 = 5-30 VDC, HTL 245 = 10-30 VDC, RS422 TTL comp. SIN = 5 V, 1 Vss Sinus (only to 1024 and 2048 PPR)
Inverted only for cable or connector: K2, L2, K3, L3, S4, S5, SB8, SC8, SB12, SC12	

Channels: AB, ABN (SIN: AB)

Pulses per revolution:
 2, 10, 15, 20, 24, 36, 40, 48, 50, 60, 64, 72, 87, 90, 100, 120, 125, 127, 128, 150, 160, 180, 200, 216, 240, 250, 254, 256, 300, 314, 320, 360, 400, 500, 512, 571, 600, 625, 720, 750, 768, 800, 810, 900, 1000, 1024, 1200, 1250, 1270, 1440, 1500, 1800, 2000, 2048, 2400, 2500, 3000, 3600, 4000, 4096, 4685, 5000.
 Other PPR's on request

Order No.:

Example	WDG 58B	500	ABN	G24	K3	
Your encoder	WDG 58B					

Options:

Low-temperature:

The encoder WDG 58B with the output switches G24, I24, G05, I05 and 245 is also available with the extended temperature range -40°C...+80°C (measured at the flange). When ordering please add the suffix code - ACA.

Shaft with flat:

The encoder WDG 58B can be supplied with a shaft with flat. When ordering please add the suffix code - AAF.

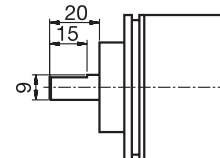

Drawing 58B-AAF

Low-friction bearings:

The encoder WDG 58B is also available as a particularly smooth-running low-friction encoder. The starting torque is thereby changed to < 0,5 Ncm and the protection class at the shaft input to IP50. When ordering please add the suffix code - AAC.

Shafts sealed to IP67:

The encoder WDG 58B can be supplied in a full IP67 version. When ordering please add the suffix code - AAO.

Max. RPM	Permitted Shaft-Loading axial	Permitted Shaft-Loading radial	Max. PPR (no 1Vss)	Starting-torque
3.500	100N	110N	2.500	ca. 4 Ncm

Amended specifications for shaft sealed to IP67.

Cable length:

The encoder WDG 58B can be supplied with more than 2 m cable. Please extend the standard order code with a three figure number, specifying the cable length in decimetres.

Electrical connections:	
Cable:	
K2 = axial, 2 m, shield not connected (standard)	
L2 = axial, 2 m, shield connected to encoder housing	
K3 = radial, 2 m, shield not connected (standard)	
L3 = radial, 2 m, shield connected to encoder housing	
Connector:	
S2 = 7-pin axial	SB4 = 4-pin axial
S3 = 7-pin radial	SC4 = 4-pin radial
S4 = 12-pin axial	SB5 = 5-pin axial
S5 = 12-pin radial	SC5 = 5-pin radial
S6 = 6-pin radial	SB8 = 8-pin axial
S7 = 4-pin axial	SC8 = 8-pin radial
	SB12 = 12-pin axial
	SC12 = 12-pin radial
Please note the connection configuration under "General technical data", Page 122	

Options:	
Empty =	without option
Low-temperature -40°C...+80°C =	ACA
Shaft with flat =	AAF
Low-friction bearings =	AAC
Shaft sealed to IP 67 =	AAO
Cable length =	in decimetres